

F A C H A D A

CORTINA

Proyecto Alcoa



ALCOA



ALCOA

Os constantes avanços da construção civil na busca da qualidade faz com que, empresas como a ALCOA busquem a melhoria e aprimoramento contínuo de seus produtos.

Agindo sempre com a preocupação de atender as necessidades do mercado, a ALCOA lança a sua nova versão da Pele de Vidro Convencional introduzindo agora o modelo com baguete.



ALCOA

excelência através da qualidade

ALCOA

A ALCOA ALUMÍNIO S.A. se reserva o direito de alterar as especificações e desenhos de seus produtos sem prévio aviso.



F A C H A D A CORTINA

ÍNDICE

Cálculo Estrutural (isopletras de ventos)	4 e 5
Laudo Técnico	6 e 7
Perfís	8 a 19
Acessórios	20 a 36

ELEVAÇÕES

Pele de Vidro	37
Cortes Sem Baguete	38 a 65
Pele de Vidro c/ Baguete	66
Cortes Com Baguete	67 a 70
Tabela de Silicone	71



COMO OBTER UM REAL DESEMPENHO DE CAIXILHOS EM EDIFICAÇÕES

Visando um real desempenho no uso e na segurança de nosso consumidor na escolha de um caixilho de alumínio mostramos as normas que devem ser seguidas dentro da EB-1968.

- 1 - Estanqueidade ao ar
norma MB-1225
- 2 - Estanqueidade á agua
norma MB-1226
- 3 - Resistência a cargas uniformemente distribuídas
norma MB-1227
- 4 - Resistência à operação de manuseio
norma MB-3065 de acordo com TB-354
- 5 - Atenuação acústica
norma MB-3051 de acordo com TB-355

Identificação da edificação para definição da região à ser instalada (figura 1).

- Após localizada a região deve-se convencionar o modelo mais adequado.
Ex. FACHADA CORTINA etc.
- Se o produto será instalado em edifício residencial/comercial e a altura dessa instalação.
Ex. Edif. c/ 20 andares
- Se as dimensões dos caixilhos estão de acordo com a linha do produto que foi adotada.

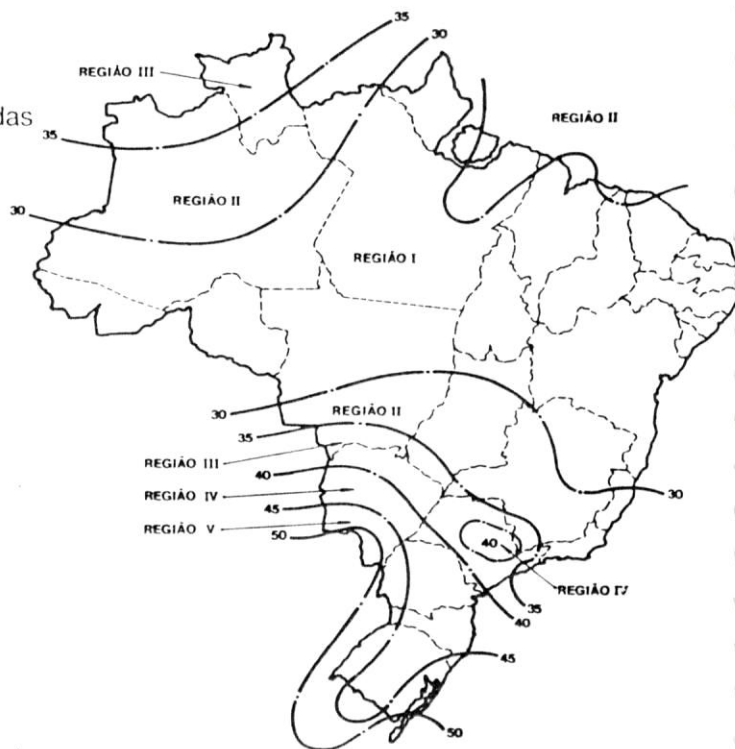

Para que esse processo de escolha venha a ocorrer de forma correta e que a resistência de cargas uniformes (ventos), não seja comprometida consideramos que:

$$V_k = V_0 \cdot S_1 \cdot S_2 \cdot S_3$$

onde:

V_k = Velocidade característica, em metros/segundos

V_0 = Velocidade básica do vento, em m/s, dada pelas isopletas da figura 1

S_1 = Fator topográfico de correção (TABELA A)

S_2 = Fator de correção que considera a influência da rugosidade do terreno, das dimensões da edificação e de sua altura sobre o terreno (TABELA B)

S_3 = Fator probabilístico, de valor igual a 0.88 (constante)

TABELA A

Topografia	S1
Vales profundos, protegidos de todos os ventos	0,9
Encostas e cristas de morro em que ocorra aceleração do vento. Vales com efeito de afunilamento.	1,1
Todos os casos, exceto os acima citados	1

TABELA B - Fator de correção - Rugosidade do terreno, dimensões da edificação e altura do terreno.

Altura acima do terreno H (m)	CATEGORIA			
	Terreno aberto sem obstruções	Terreno aberto com poucas obstruções	Terreno com muitas obstruções pequenas, cidades, subúrbios de grandes cidades	Terreno com obstruções grandes e frequentes. Ex. centro de grandes cidades
3	0,83	0,72	0,64	0,56
5	0,88	0,79	0,70	0,60
10	1,00	0,93	0,78	0,67
15	1,03	1,00	0,86	0,74
20	1,06	1,03	0,95	0,79
30	1,09	1,07	1,01	0,90
40	1,12	1,10	1,05	0,97
50	1,14	1,12	1,08	1,02
60	1,15	1,14	1,10	1,05
80	1,18	1,17	1,13	1,10
100	1,20	1,19	1,16	1,13
120	1,22	1,21	1,18	1,15
140	1,24	1,22	1,20	1,17
160	1,25	1,24	1,21	1,19
180	1,26	1,25	1,23	1,20
200	1,27	1,26	1,24	1,22

$$q = \frac{(Vk)^2}{1.6} \quad \text{onde:}$$

q = pressão de obstrução, em Pascais

$$p = q \times (Ce-Ci) \quad \text{onde:}$$

p = pressão de ensaio, em Pascais

(Ce-Ci) = coeficiente aerodinâmico que leva em conta a posição do caixilho e as dimensões da edificação. Dados fornecidos pelo calculista da construtora. Valor para condições mais desfavoráveis = 1,5

Exemplo: Edifício de 20 andares (~ 60 metros de altura) contruído em terreno aberto com poucas obstruções em São Paulo.

Dados: $V_0 = 40$ m/s (figura 1)

$$S_1 = 1 \text{ (tabela A)}$$

$$S_2 = 1,14 \text{ (tabela B)}$$

$$S_3 = 0,88 \text{ (constante)}$$

Temos:

$$Vk = 40 \cdot 1 \cdot 1,14 \cdot 0,88$$

$$Vk = 40 \text{ m/s}$$

$$q = \frac{(40)^2}{1.6}$$

$$q = 1000 \text{ Pa}$$

$$p = 1000 \cdot 1,1 \text{ (fornecido pelo calculista)}$$

$$p = 1100 \text{ Pa}$$

Nessa condições os caixilhos serão submetidos à testes com um pressor de 1100 Pascais (Pa)

JX - 0.2899 CM ⁴
JY - 1.1186 CM ⁴
WX - 0.3096 CM ³
WY - 0.6442 CM ³

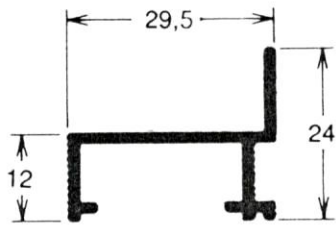

CM-102 0,247 Kg/ml
Contramarco

JX - 0.3243 CM ⁴
JY - 1.5099 CM ⁴
WX - 0.3436 CM ³
WY - 0.8530 CM ³

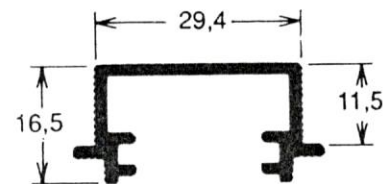

CM-103 0,288 Kg/ml
Contramarco

JX - 0.1146 CM ⁴
JY - 0.6185 CM ⁴
WX - 0.3598 CM ³
WY - 0.5579 CM ³

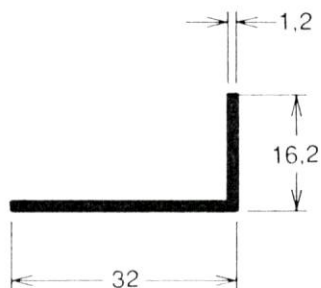

CT-209 0,152 Kg/ml
Cantoneira

JX - 2.8815 CM ⁴
JY - 5.7373 CM ⁴
WX - 1.668 CM ³
WY - 1.9681 CM ³

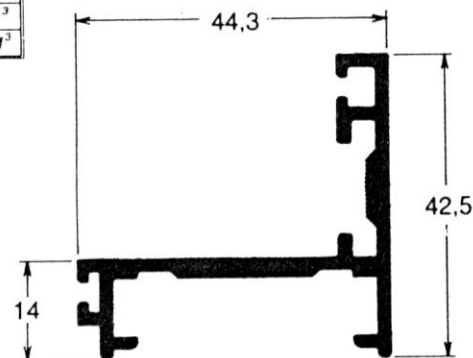

FC-225 0,640 Kg/ml
Marco Vertical Horizontal

JX - 1.1811 CM ⁴
JY - 0.0957 CM ⁴
WX - 3.6262 CM ³
WY - 0.0485 CM ³

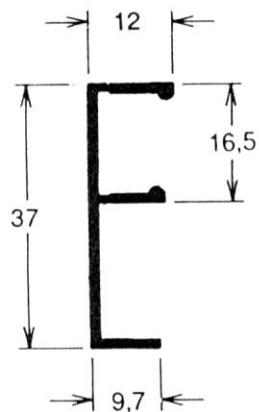

MP-347 0,202 Kg/ml
Remate Clicado

JX - 0.803 CM ⁴
JY - 4.044 CM ⁴
WX - 0.203 CM ³
WY - 0.356 CM ³

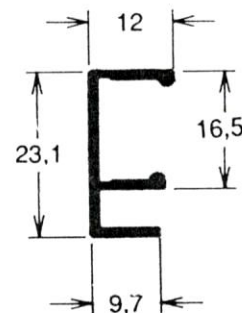

ME-092 0,160 Kg/ml
Remate Clicado

JX- 423.2380 CM ⁴
JY- 110.7310 CM ⁴
WX- 45.708 CM ³
WY- 29.528 CM ³

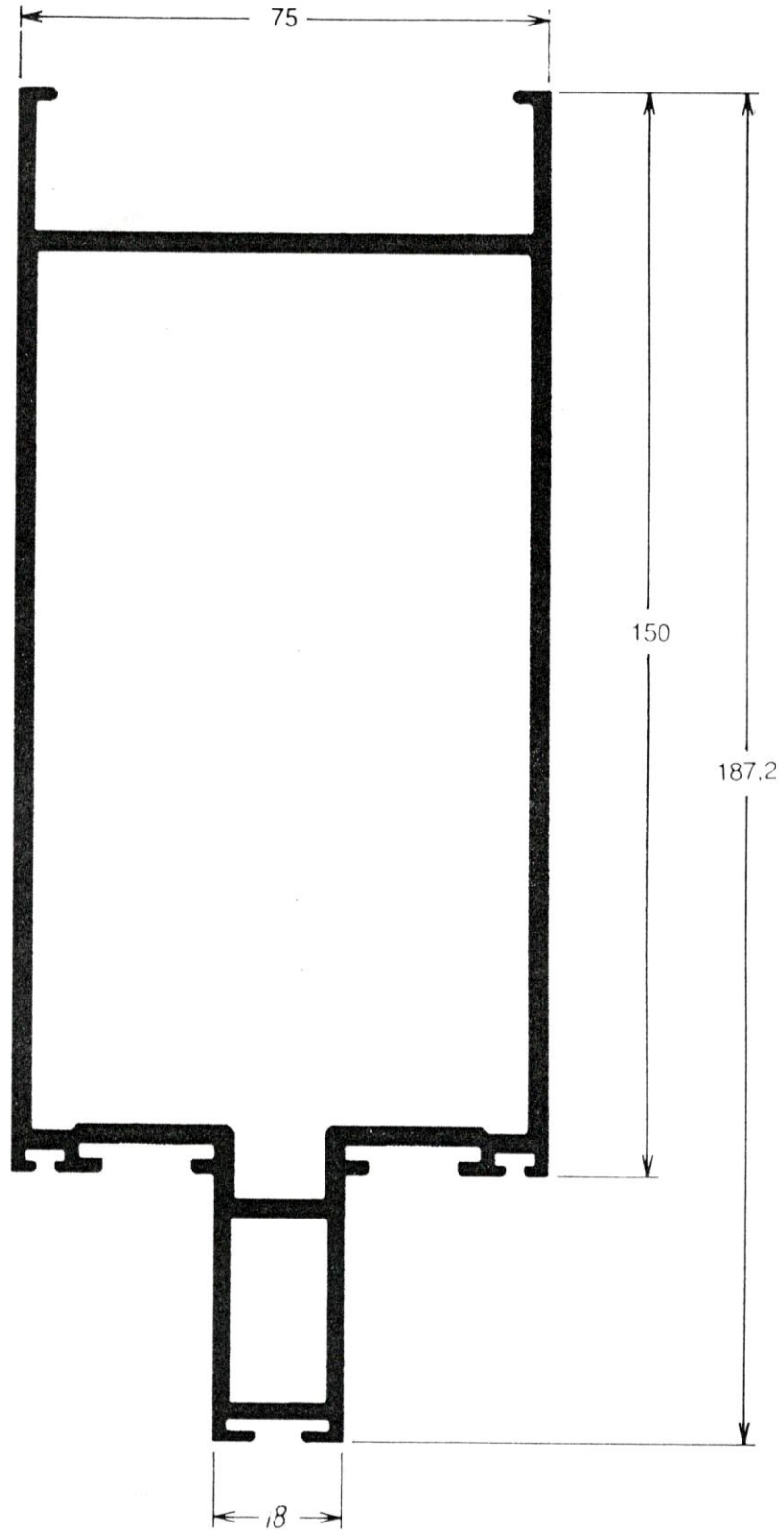

FC-233 3,494 Kg/ml
Coluna Reforçada

JX	11.7259 CM ⁴
JY	11.9607 CM ⁴
WX	3.5946 CM ³
WY	3.8322 CM ³

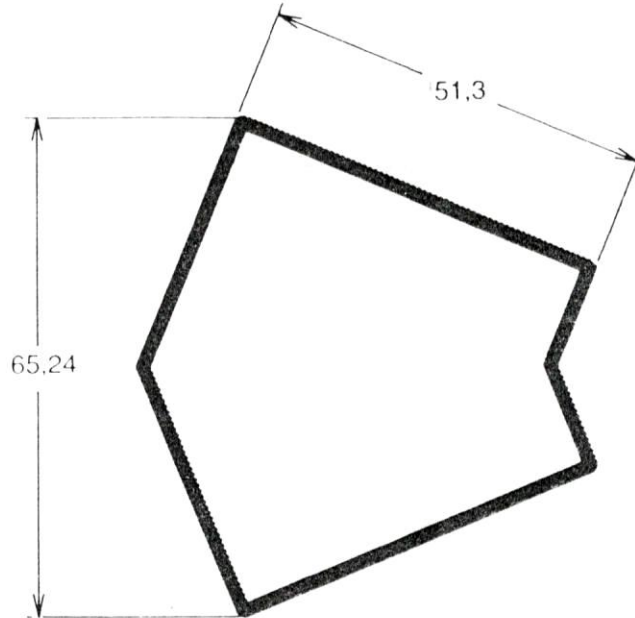

FC-240 0,799 Kg/ml
Coluna 135°

JX	15.3844 CM ⁴
JY	15.3844 CM ⁴
WX	6.0568 CM ³
WY	6.0568 CM ³

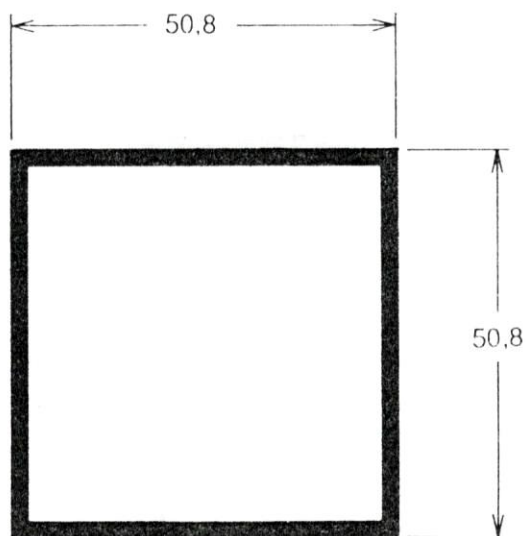

TQ-017 1,042 Kg/ml
Coluna 90°

JX - 50.8925 CM ⁴
JY - 50.8925 CM ⁴
WX - 8.7288 CM ³
WY - 8.7288 CM ³

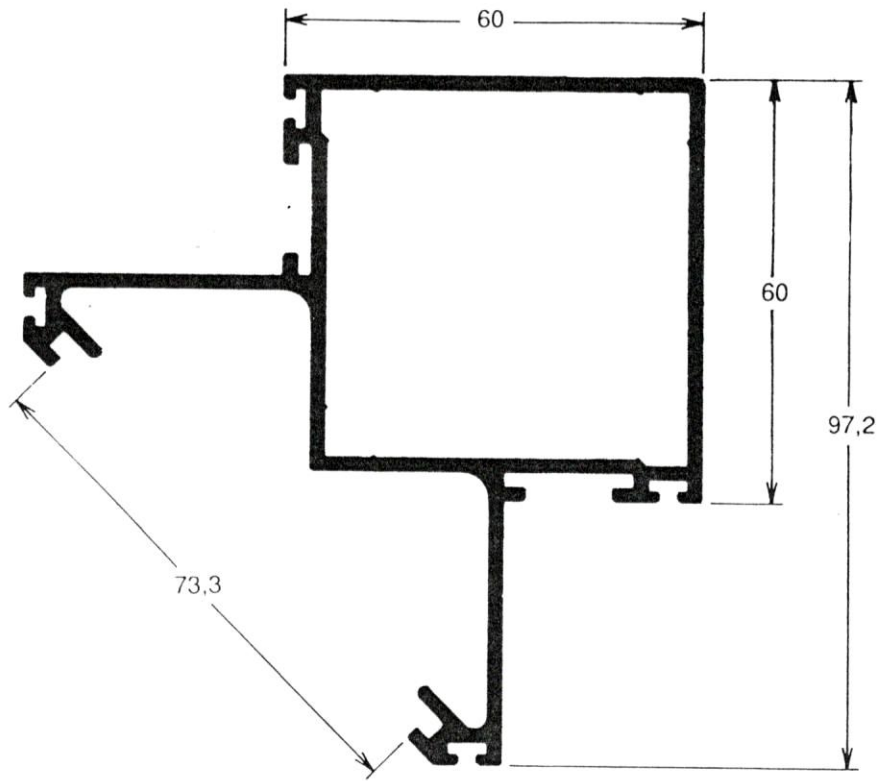

FC-244 1,786 Kg/ml
Coluna 90°

JX - 42.1912 CM ⁴
JY - 7.7748 CM ⁴
WX - 8.2901 CM ³
WY - 4.0670 CM ³

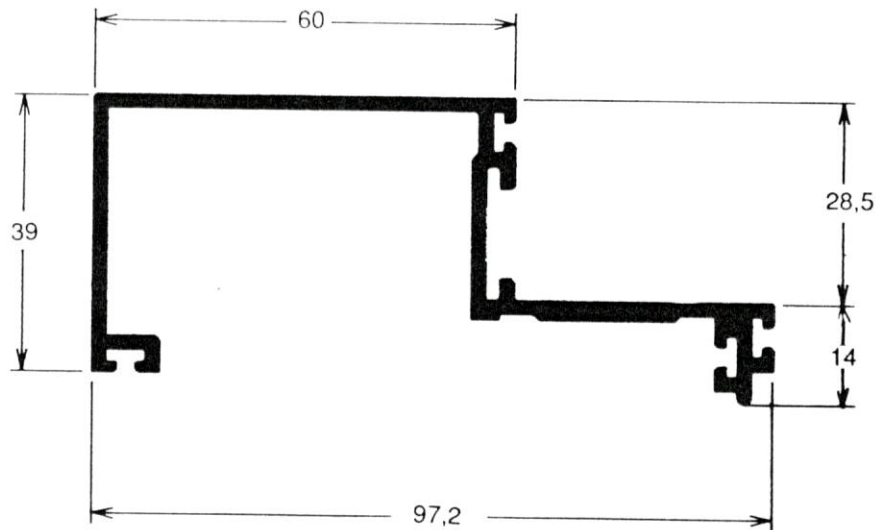

FC-259 1,067 Kg/ml
Coluna lateral

JX - 0.084 CM ⁴
JY - 7.2616 CM ⁴
WX - 0.3653 CM ³
WY - 2.1357 CM ³



FC-205 0,502 kg/ml
Complemento Horizontal

JX - 1.4713 CM ⁴
JY - 3.1290 CM ⁴
WX - 0.7663 CM ³
WY - 1.7517 CM ³

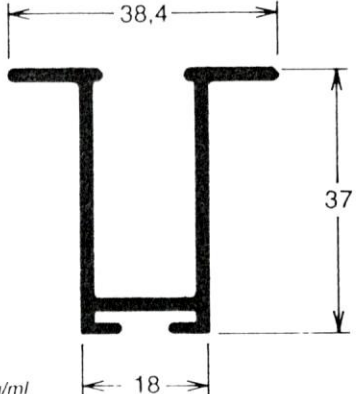

FC-204 0,482 Kg/ml
Complemento Horizontal

JX - 8.4727 CM ⁴
JY - 12.6894 CM ⁴
WX - 2.7759 CM ³
WY - 3.3838 CM ³

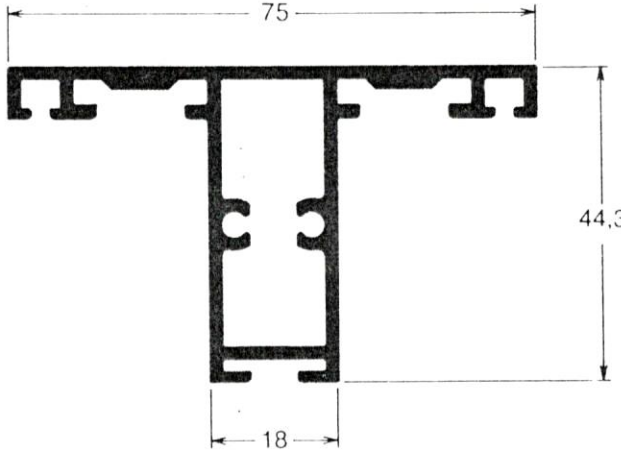

FC-231 1,062 Kg/ml
Marco Vertical

JX - 14.0113 CM ⁴
JY - 21.3044 CM ⁴
WX - 3.7655 CM ³
WY - 5.6811 CM ³

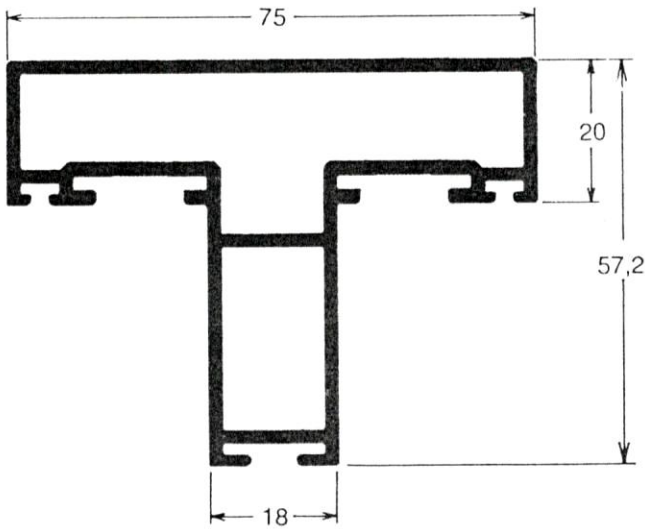

FC-232 1,302 Kg/ml
Coluna

JX	64.4055 CM ²
JY	28.8105 CM ²
WX	13.5172 CM ³
WY	7.6828 CM ³

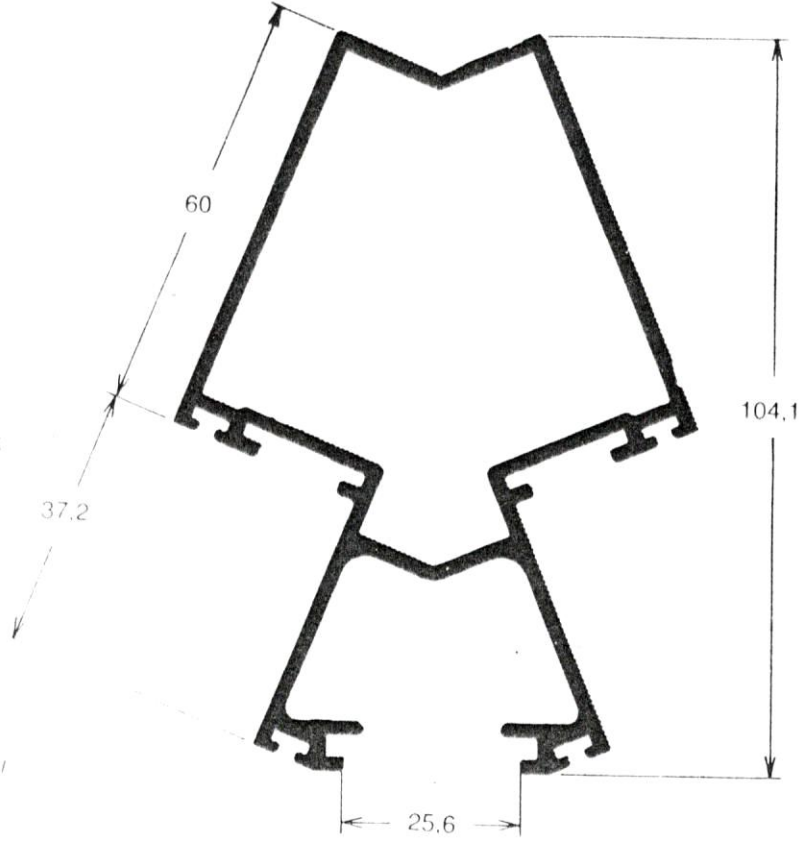

FC-241 1,807 Kg/ml
Coluna 45

JX	62.3775 CM ²
JY	42.3961 CM ²
WX	11.7272 CM ³
WY	11.3150 CM ³

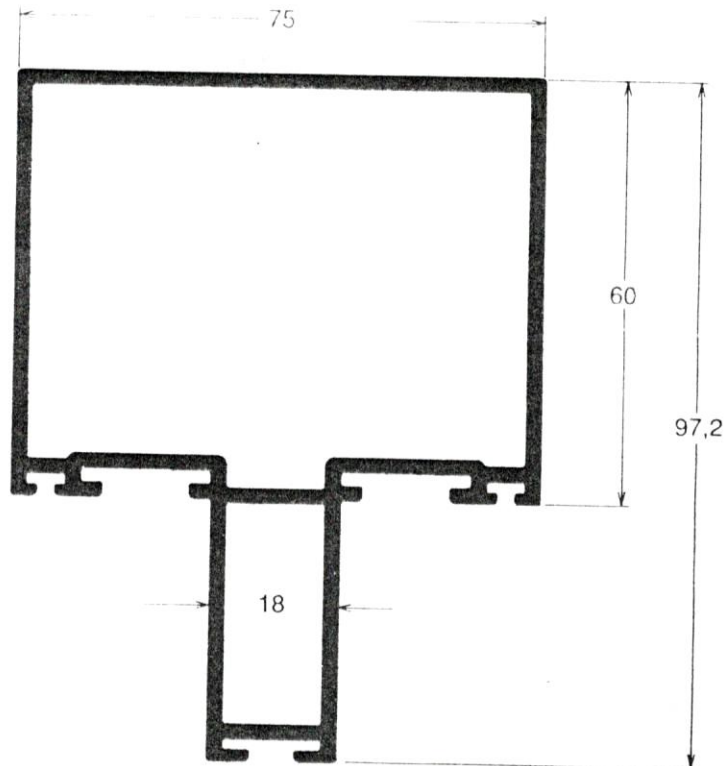

FC-202 1,821 Kg/ml
Coluna

JX - 3.3370 CM ⁴
JY - 0.0198 CM ⁴
WX - 1.1123 CM ³
WY - 0.1620 CM ³

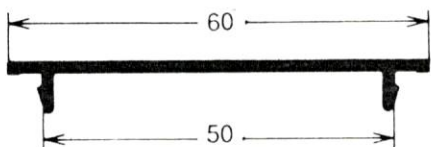

FC-085 0,256 Kg/ml
Tampa do Rodapé e Forro

JX - 0.0134 CM ⁴
JY - 6.5919 CM ⁴
WX - 1.7578 CM ³
WY - 0.0271 CM ³

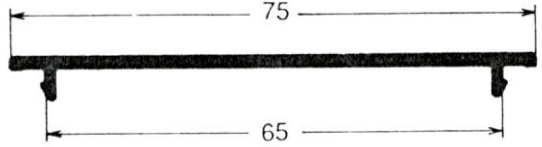

FC-234 0,339 Kg/ml
Tampa para coluna

JX - 1.2611 CM ⁴
JY - 2.8352 CM ⁴
WX - 1.3255 CM ³
WY - 1.2030 CM ³

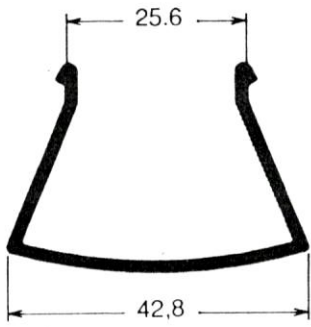

FC-239 0,378 Kg/ml
Tampa para coluna

JX - 5.6110 CM ⁴
JY - 39.2175 CM ⁴
WX - 7.1921 CM ³
WY - 3.2832 CM ³

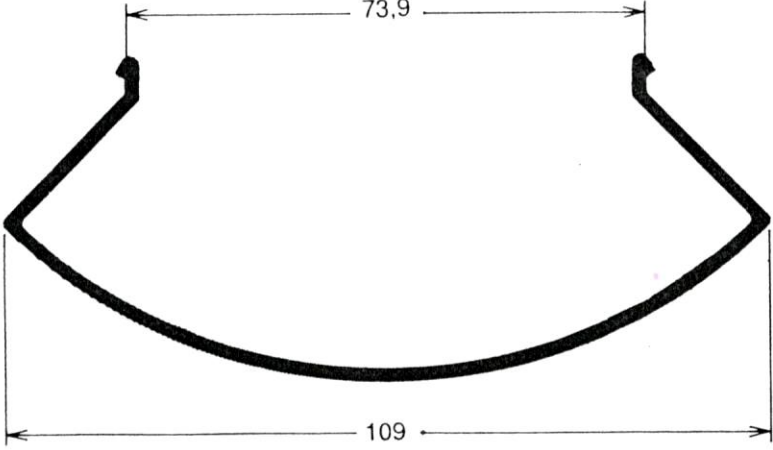

FC-242 0,791 Kg/ml
Tampa para Coluna 90°

JX - 2,8961 CM ⁴
JY - 7,6815 CM ⁴
WX - 1,3995 CM ³
WY - 2,7895 CM ³

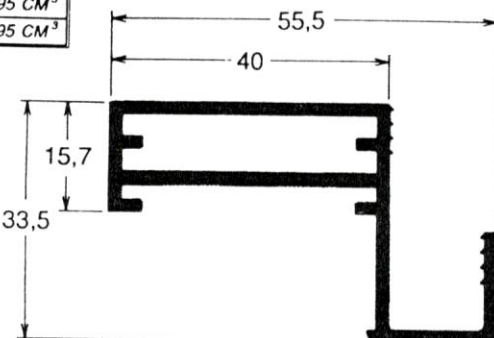

FC-207 0,701 Kg/ml
Travessa Horizontal Folha Móvel e Fixa

JX - 3,1648 CM ⁴
JY - 8,1723 CM ⁴
WX - 1,4558 CM ³
WY - 3,0563 CM ³

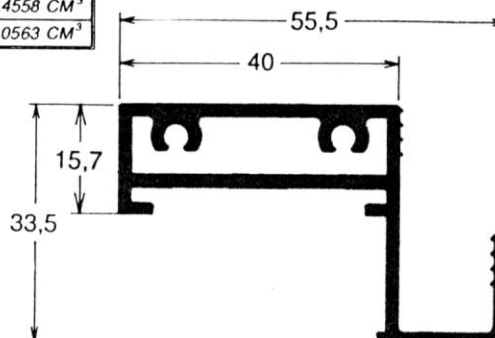

FC-208 0,783 Kg/ml
Montante Vertical Folha Fixa

JX - 6,1796 CM ⁴
JY - 2,8617 CM ⁴
WX - 2,3006 CM ³
WY - 2,2248 CM ³

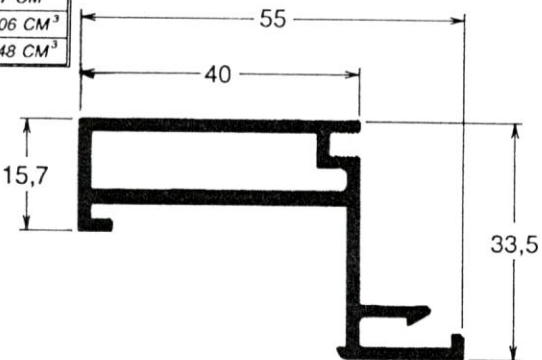

FC-254 0,643 Kg/ml
Montante e Travessa Folha

JX - 0,0430 CM ⁴
JY - 0,0843 CM ⁴
WX - 0,2939 CM ³
WY - 0,0597 CM ³

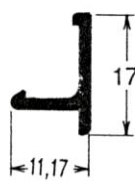

FC-237 0,109 Kg/ml
Baguete

JX - 0,1072 CM ⁴
JY - 11,0204 CM ⁴
WX - 2,4896 CM ³
WY - 0,2059 CM ³

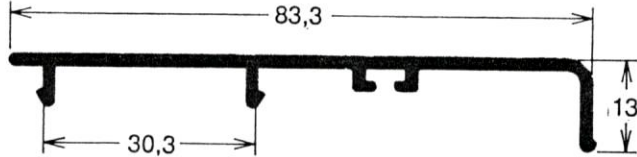

FC-229 0,461 Kg/ml
Pingadeira da Folha Fixa

JX - 11.0441 CM ⁴
JY - 0.1198 CM ⁴
WX - 2.8130 CM ³
WY - 0.1962 CM ³

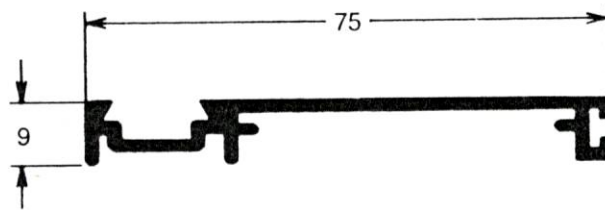

FC-258 0,485 Kg/ml
Remate de Canto

JX - 0.6270 CM ⁴
JY - 38.0680 CM ⁴
WX - 0.5975 CM ³
WY - 6.6835 CM ³

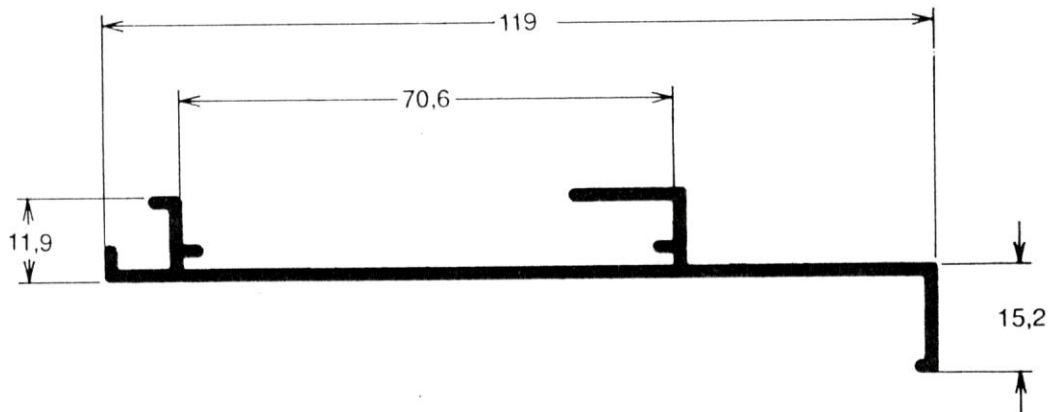

FC-257 0,747Kg/ml
Tampa Lateral

JX - 0.5679 CM ⁴
JY - 7.8038 CM ⁴
WX - 1.1453 CM ³
WY - 2.6012 CM ³

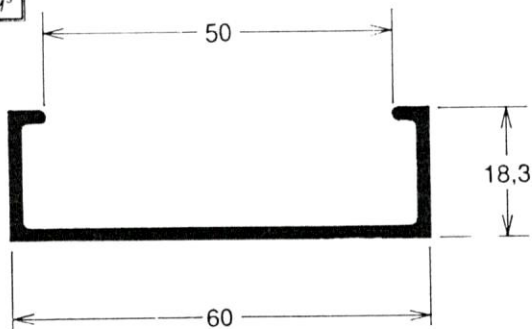

FC-256 0,410 Kg/ml
Rodapé

JX - 5.1518 CM ⁴
JY - 5.1518 CM ⁴
WX - 3.8318 CM ³
WY - 3.8318 CM ³

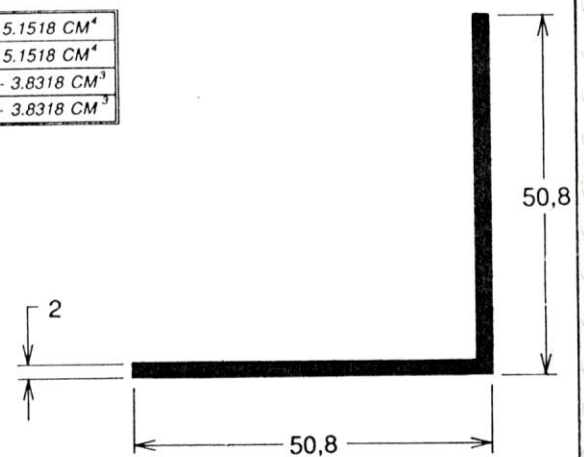

CT-031 0,540 Kg/ml
Cantoneira

JX - 13.8452 CM ⁴
JY - 5.8384 CM ⁴
WX - 1.8861 CM ³
WY - 5.3440 CM ³

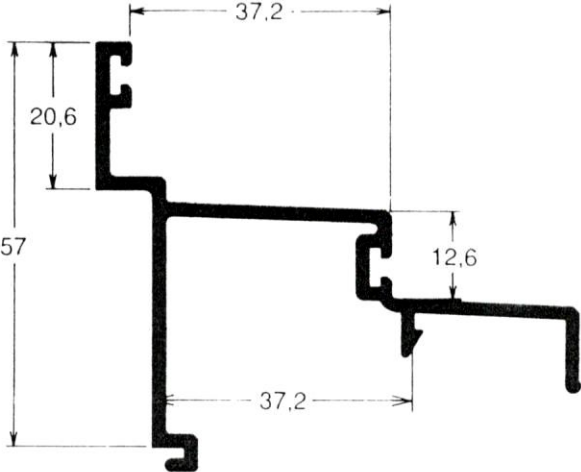

FC-222 0,788 Kg/ml
Pingadeira Folha Fixa

JX - 19.2853 CM ⁴
JY - 5.9006 CM ⁴
WX - 2.1326 CM ³
WY - 6.6074 CM ³

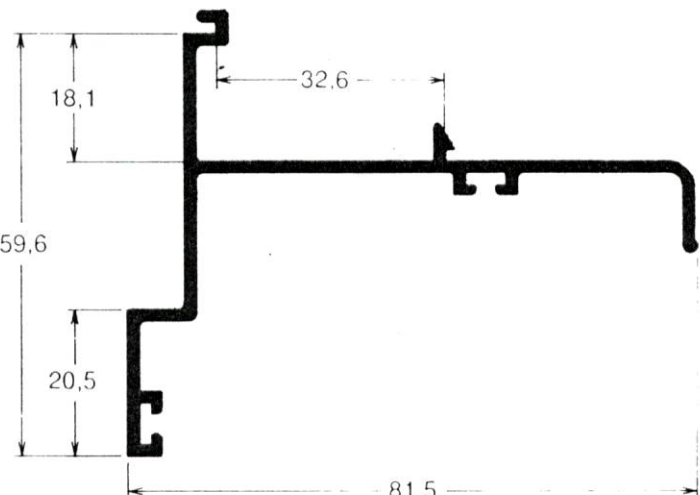

FC-226 0,749 Kg/ml
Pingadeira Folha Fixa

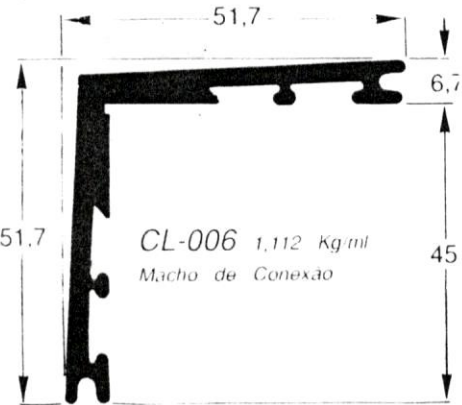

CL-006 1,112 Kg/ml
Macho de Conexão



CL-011 0,320 Kg/ml
Cunha de Conexão

JX - 1.5185 CM ⁴
JY - 34.2093 CM ⁴
WX - 0.9926 CM ³
WY - 6.2098 CM ³

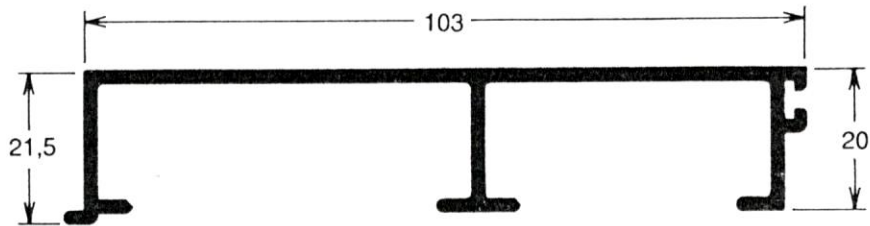

FC-246 0,766 Kg/ml
Remate do Rodapé e Forro

JX - 8.6164 CM ⁴
JY - 0.8755 CM ⁴
WX - 1.3603 CM ³
WY - 2.8403 CM ³

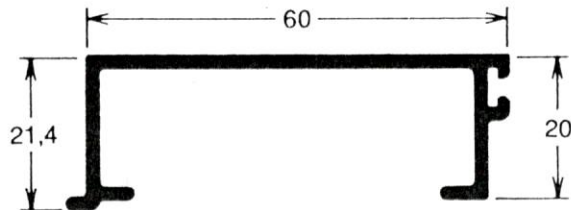

FC-247 0,444 Kg/ml
Remate do Rodapé e Forro

JX - 1.4077 CM ⁴
JY - 55.336 CM ⁴
WX - 0.9096 CM ³
WY - 8.8356 CM ³

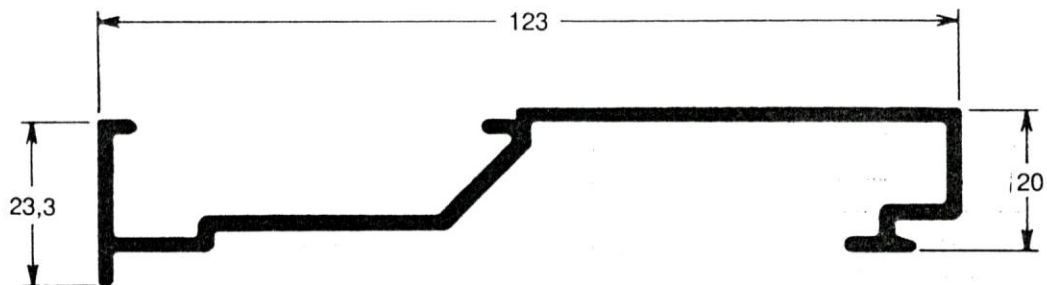

FC-250 0,836 Kg/ml
Rodapé

Perfis

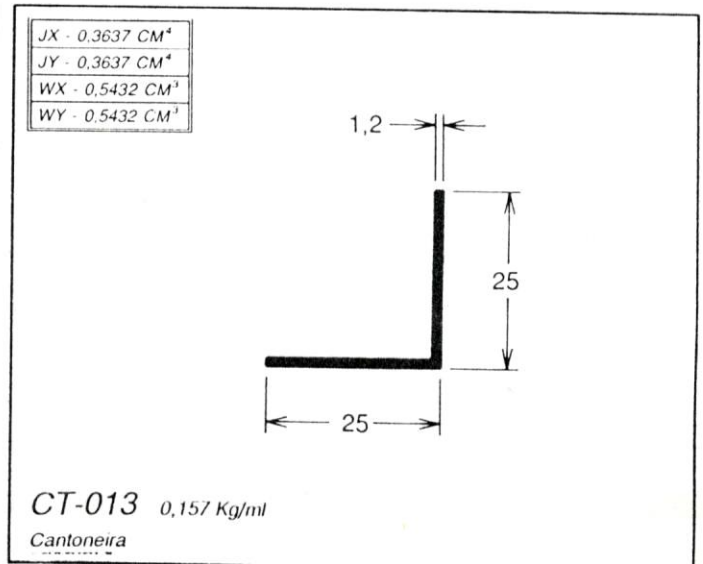
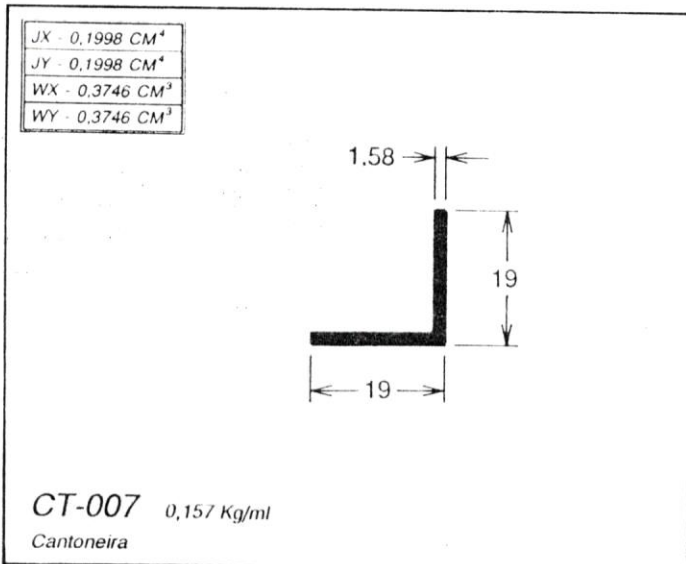
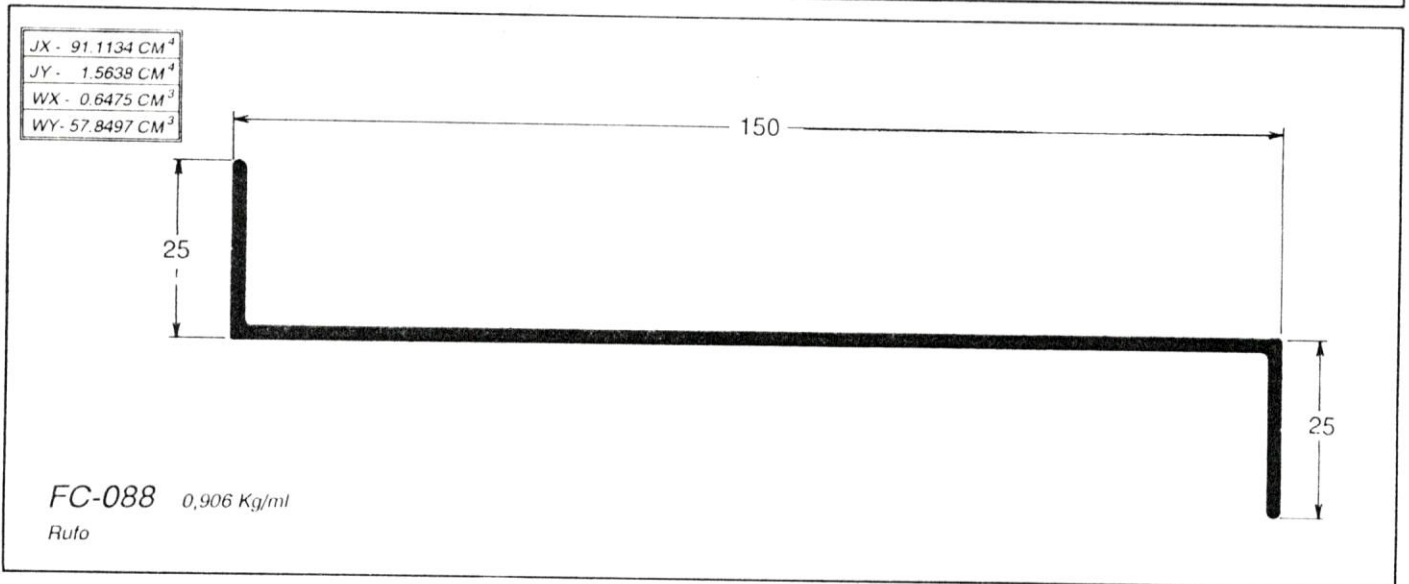
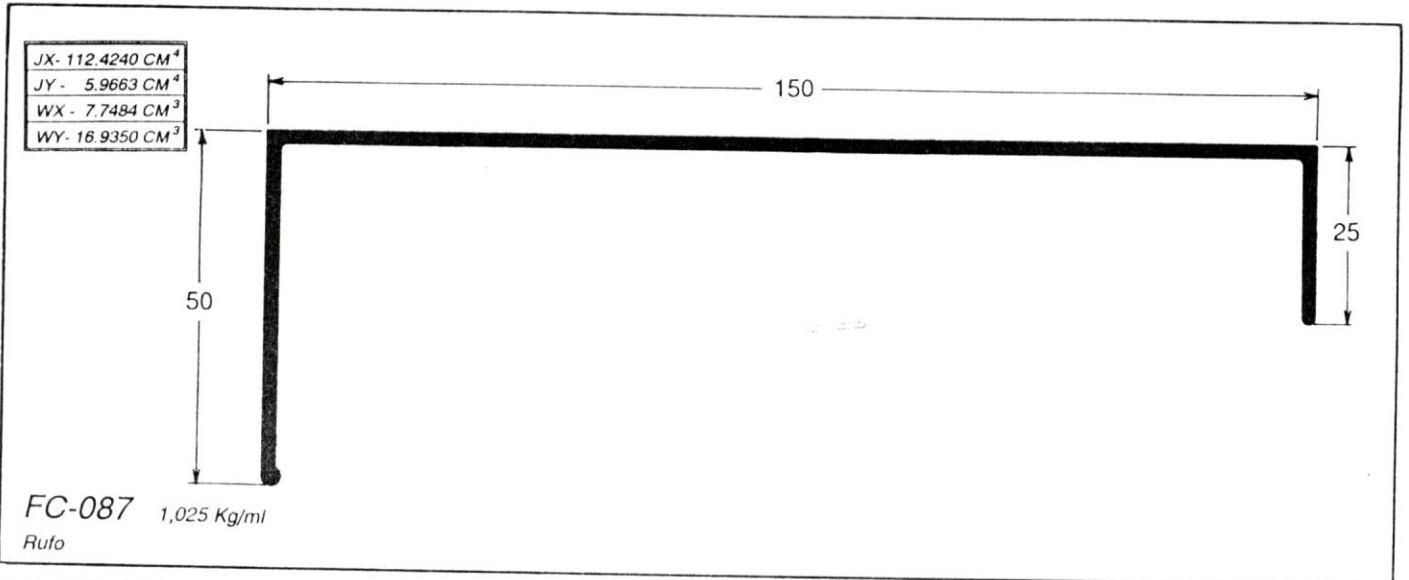

Peso da folha com vidro 8 mm = 41,5 Kg.

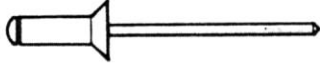

REB-152 [Alumínio]
Rebite Pop Cabeça Chata
NPAK 650S Ø 4.8 x 12.8

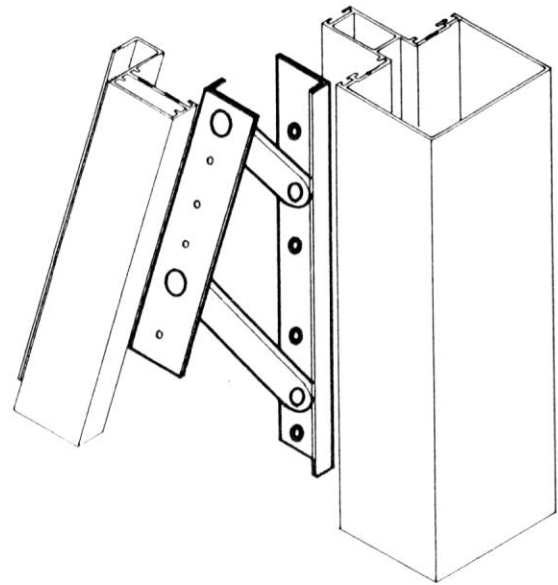
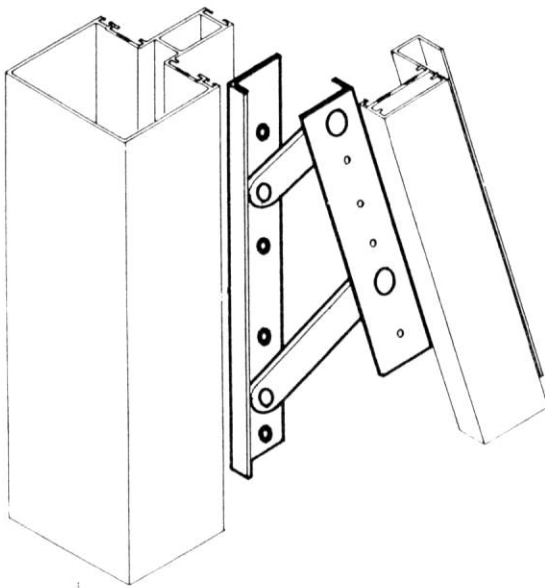
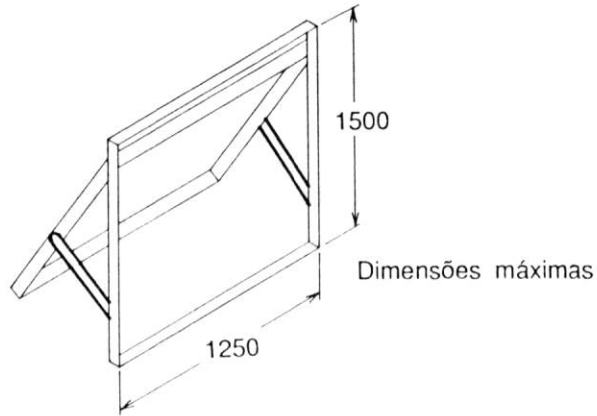

BRAÇO SIMPLES PARA FOLHA COM H ATÉ 1500 mm

CONJUNTO	A	ALTURA DA FOLHA	PERFIS
BRA-618	400	650 A 800 mm	
BRA-621	600	800 A 1000 mm	
BRA-624	950	1000 A 1500 mm	

CONJUNTO	A	ALTURA DA FOLHA	PERFIS
BRA-620	400	650 A 800 mm	
BRA-623	600	800 A 1000 mm	
BRA-626	950	1000 A 1500 mm	

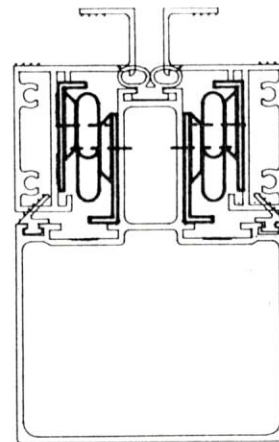

Peso da folha com vidro 8 mm = 41.5 Kg.

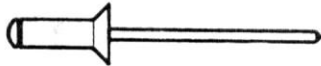

REB-152 [Aluminio]
Rebite Pop Cabeça Chata
NPAK 650S Ø 4.8 x 12.8

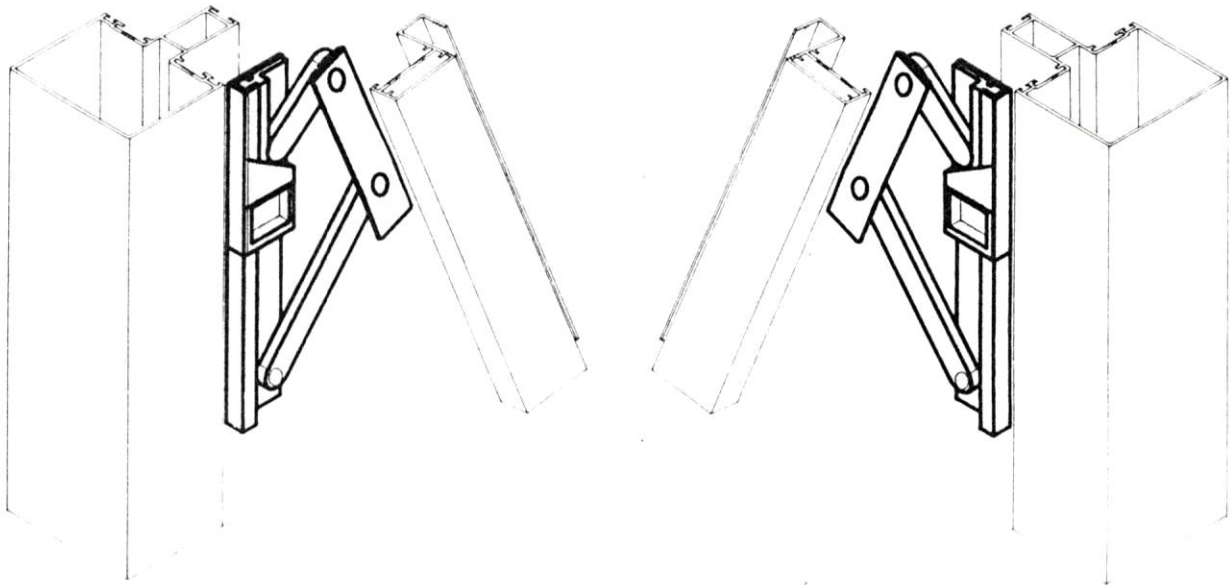
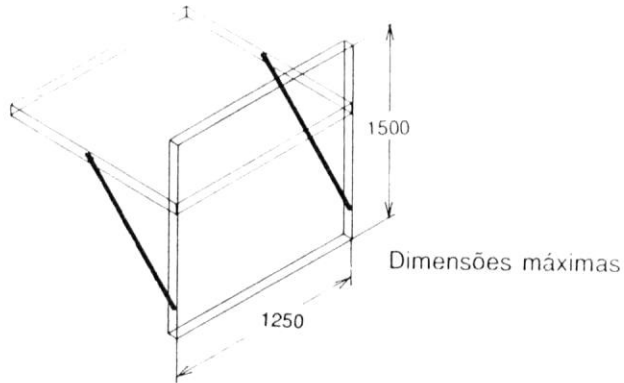

BRAÇO SIMPLES PARA FOLHA COM H ATÉ 1500 mm
COM REVERSÃO A 90°

CONJUNTO	A	ALTURA DA FOLHA	FOSCO
BRA-534	400	650 A 800 mm	
BRA-537	600	800 A 1000 mm	
BRA-540	950	1000 A 1500 mm	

CONJUNTO	A	ALTURA DA FOLHA	PRETO
BRA-536	400	650 A 800 mm	
BRA-539	600	800 A 1000 mm	
BRA-542	950	1000 A 1500 mm	

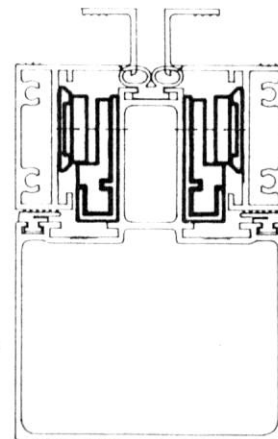

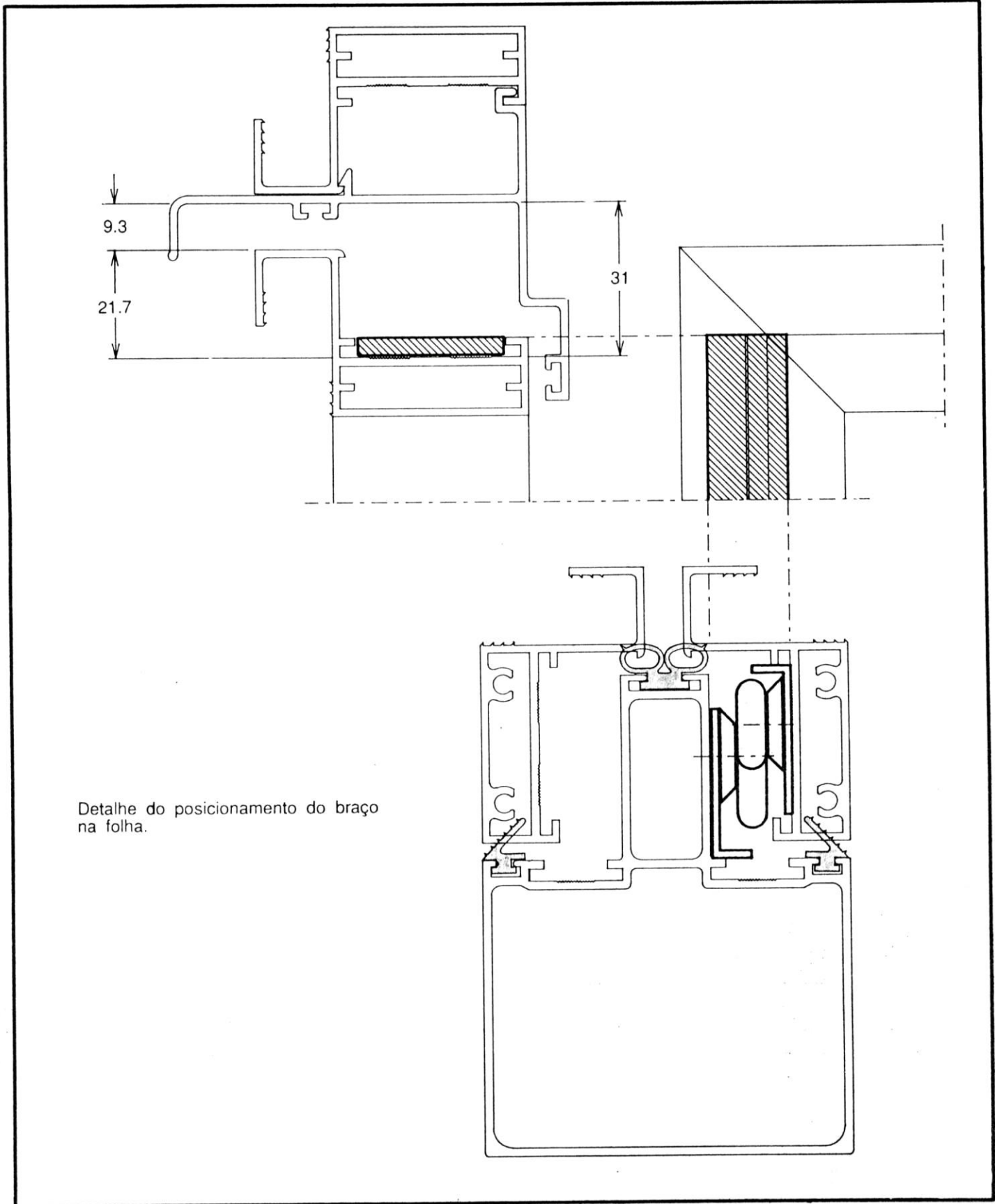

Detalhe do posicionamento do braço na folha.

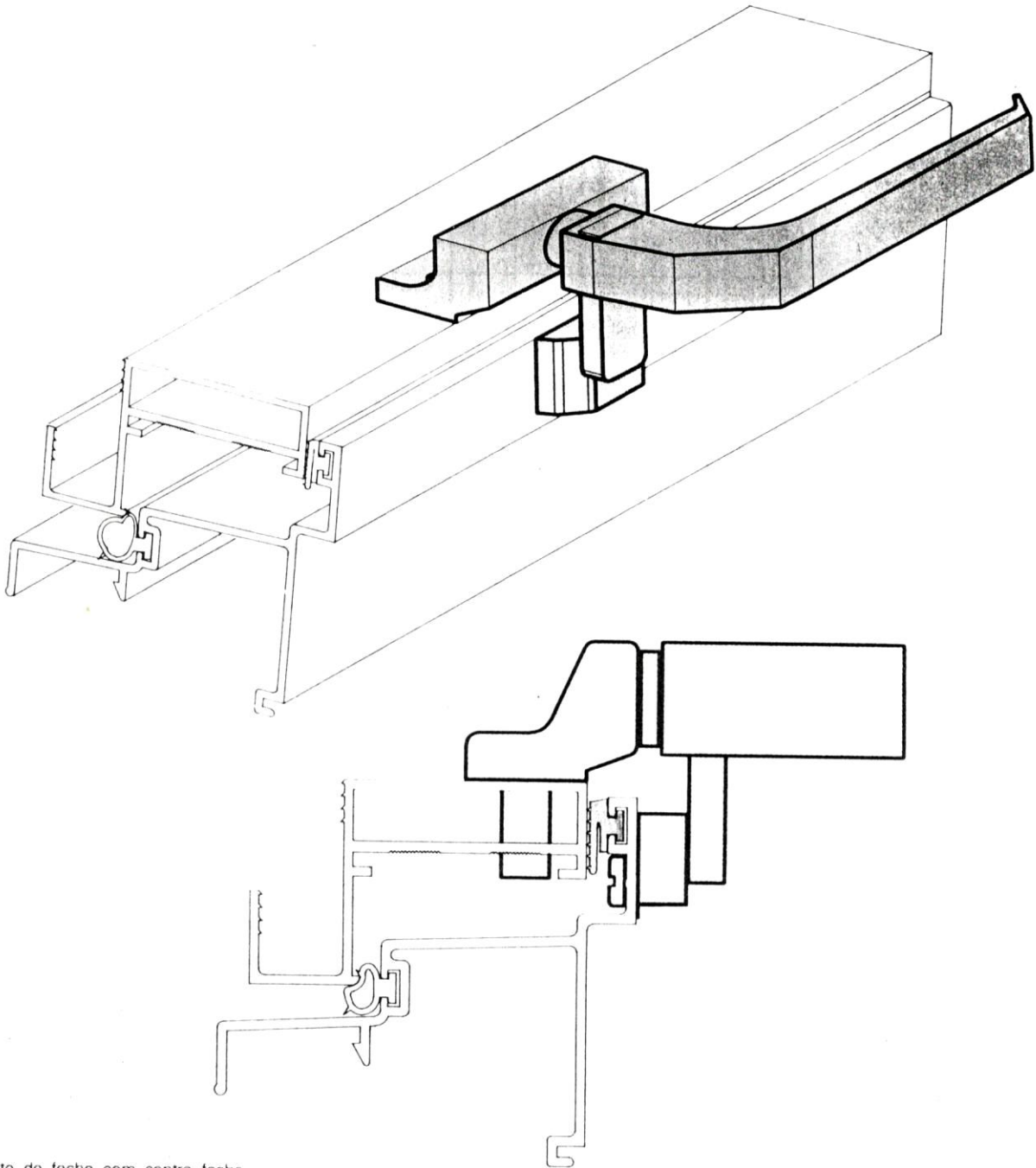

Conjunto de fecho com contra fecho
bucha rosqueada de repuxo e parafusos.

DIREITO	ESQUERDO	ANOD
FEC-150	FEC-153	FOSCO
FEC-152	FEC-155	PRETO

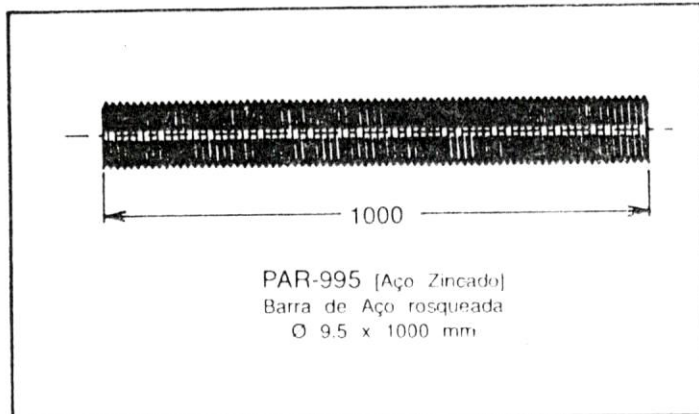

PAR-995 [Aço Zincado]
Barra de Aço rosqueada
Ø 9.5 x 1000 mm

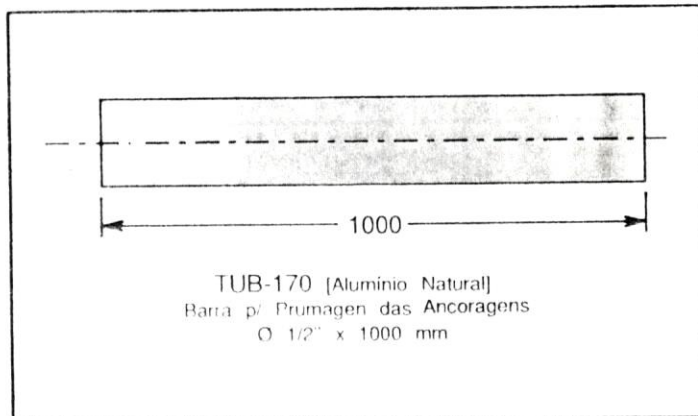

TUB-170 [Alumínio Natural]
Barra p/ Prumagen das Ancoragens
Ø 1/2" x 1000 mm

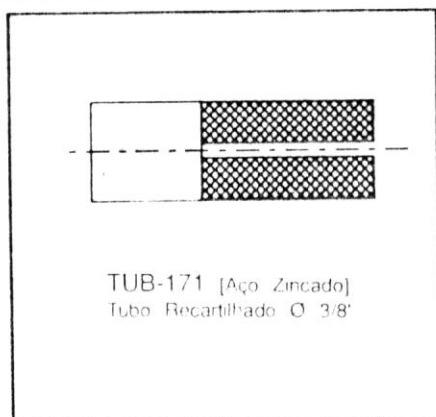

TUB-171 [Aço Zincado]
Tubo Recartilhado Ø 3/8"

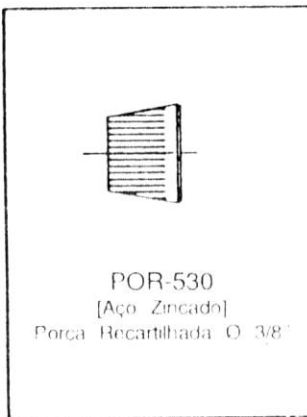

POR-530
[Aço Zincado]
Porca Recartilhada Ø 3/8"

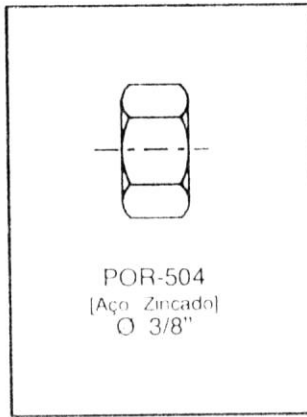

POR-504
[Aço Zincado]
Ø 3/8"



ARR-556
[Aço Zincado]
Arruela Lisa Ø 3/8"

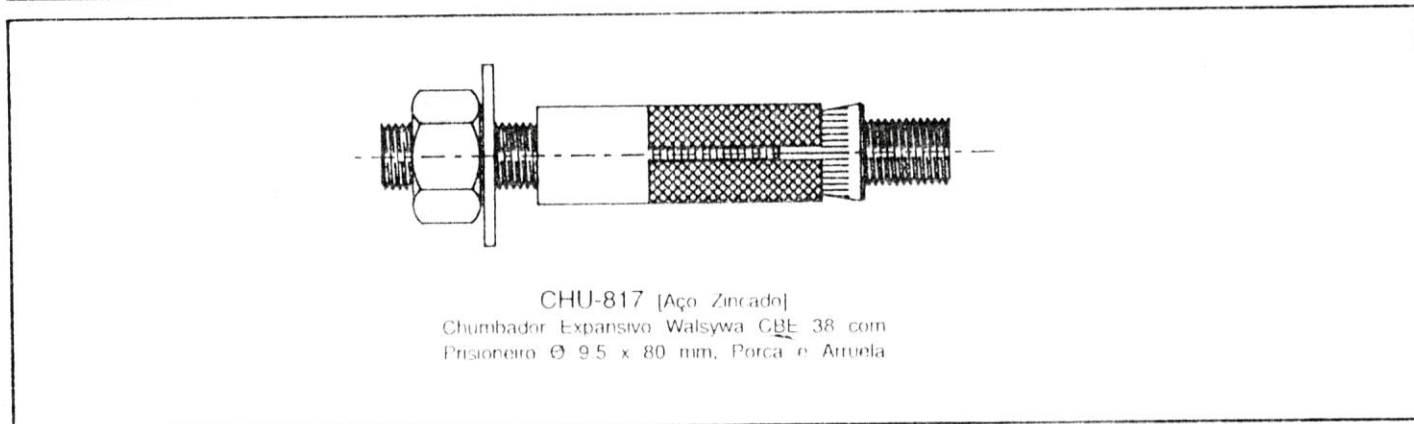

CHU-817 [Aço Zincado]
Chumbador Expansivo Walsywa CBE 38 com
Prisioneiro Ø 9.5 x 80 mm, Porca e Arruela

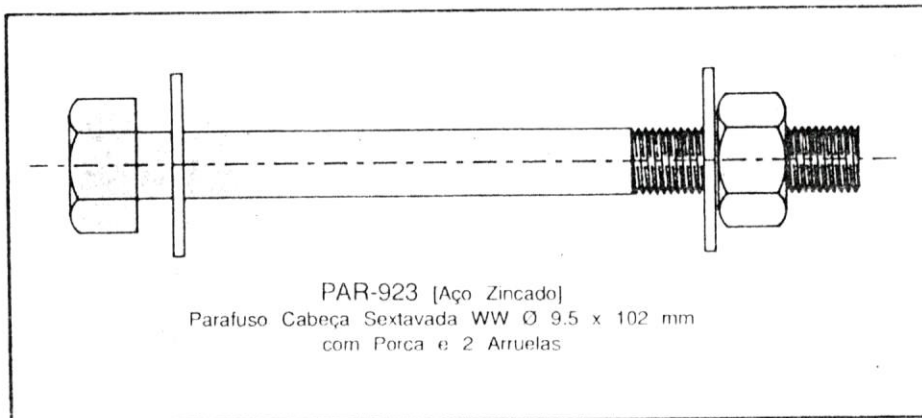

PAR-923 [Aço Zincado]
Parafuso Cabeça Sextavada WW Ø 9.5 x 102 mm
com Porca e 2 Arruelas

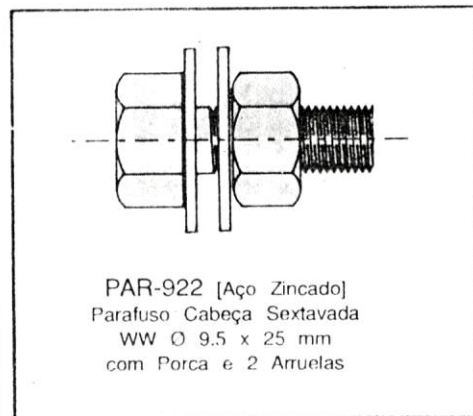

PAR-922 [Aço Zincado]
Parafuso Cabeça Sextavada
WW Ø 9.5 x 25 mm
com Porca e 2 Arruelas

Acessórios



PAR-218 [Aço Zincado]
Parafuso Auto Atar. Cab. Painela
com Fenda Ø 4.2x9.5 mm



PAR-228 [Aço Zincado]
Parafuso Auto Atar. Cab. Painela
com Fenda Ø 4.8x13 mm



PAR-220 [Aço Zincado]
Parafuso Auto Atar. Cab. Painela
com Fenda Ø 4.2x16 mm



PAR-232 [Aço Zincado]
Parafuso Auto Atar. Cab. Painela
com Fenda Ø 4.8x25 mm



PAR-233 [Aço Zincado]
Parafuso Auto Atar. Cab. Painela
com Fenda Ø 4.8x32 mm

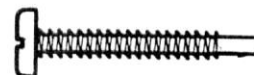

PAR-427 [Aço Zincado]
Parafuso Auto Atar. Cab. Painela com
Fenda Ø 4.8x32 mm Ponta Paralela

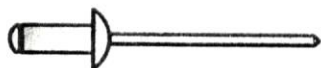

REB-078 [Alumínio]
Rebite Pop Cabeça Abaulada
EAD 540 S Ø 3.2x5.9

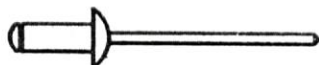

REB-088 [Alumínio]
Rebite Pop Cabeça Abaulada
EAD 540 S Ø 4x7.4



BUC-755
Buchta de Nylon S8



REB-089 [Alumínio]
Rebite Pop Cabeça Abaulada
EAD 540 S Ø 4x10.2

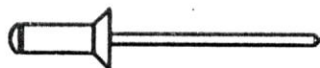

REB-152 [Alumínio]
Rebite Pop Cabeça Chata
NPAK 650S Ø 4.8x12.8

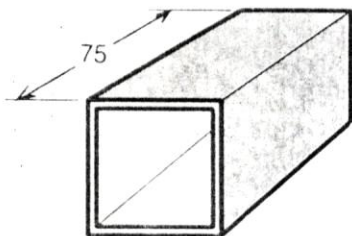

ESP-971
Espaçador



NYL-042
Botão Tampa furo em Nylon Preto

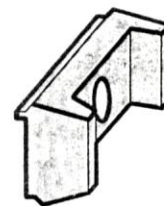

NYL-190
Botão de Fixação do Remate
em Nylon Preto

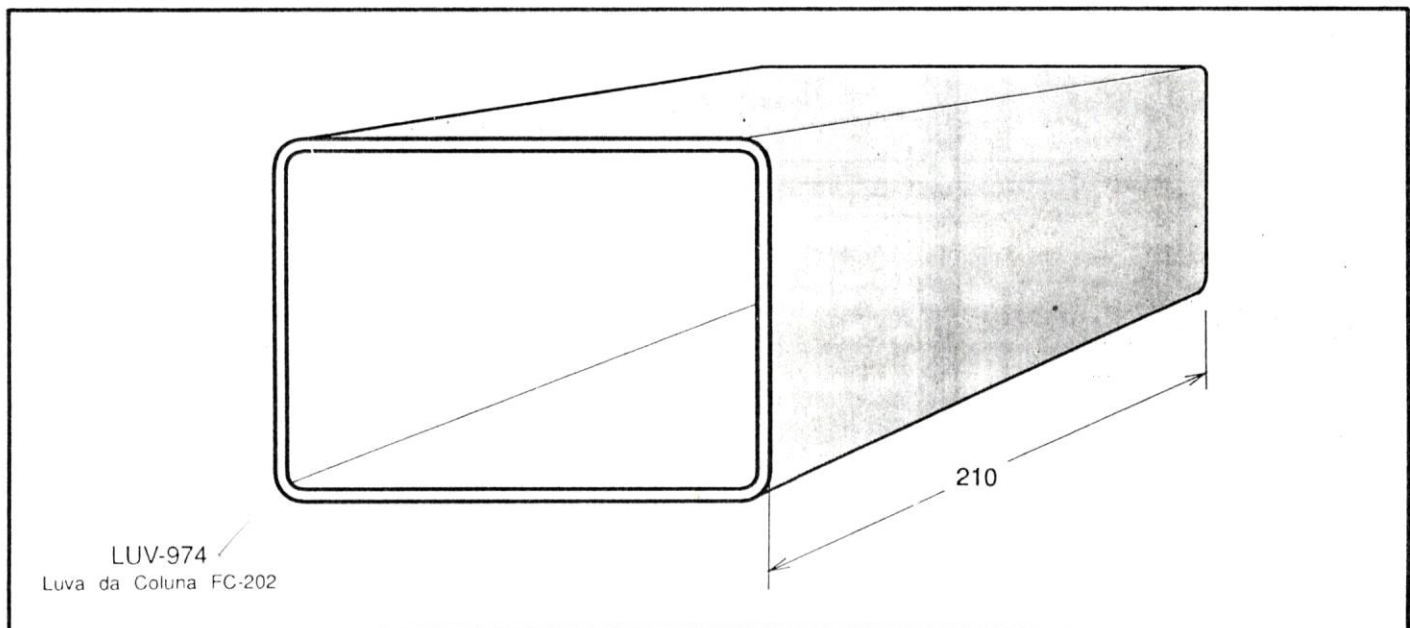
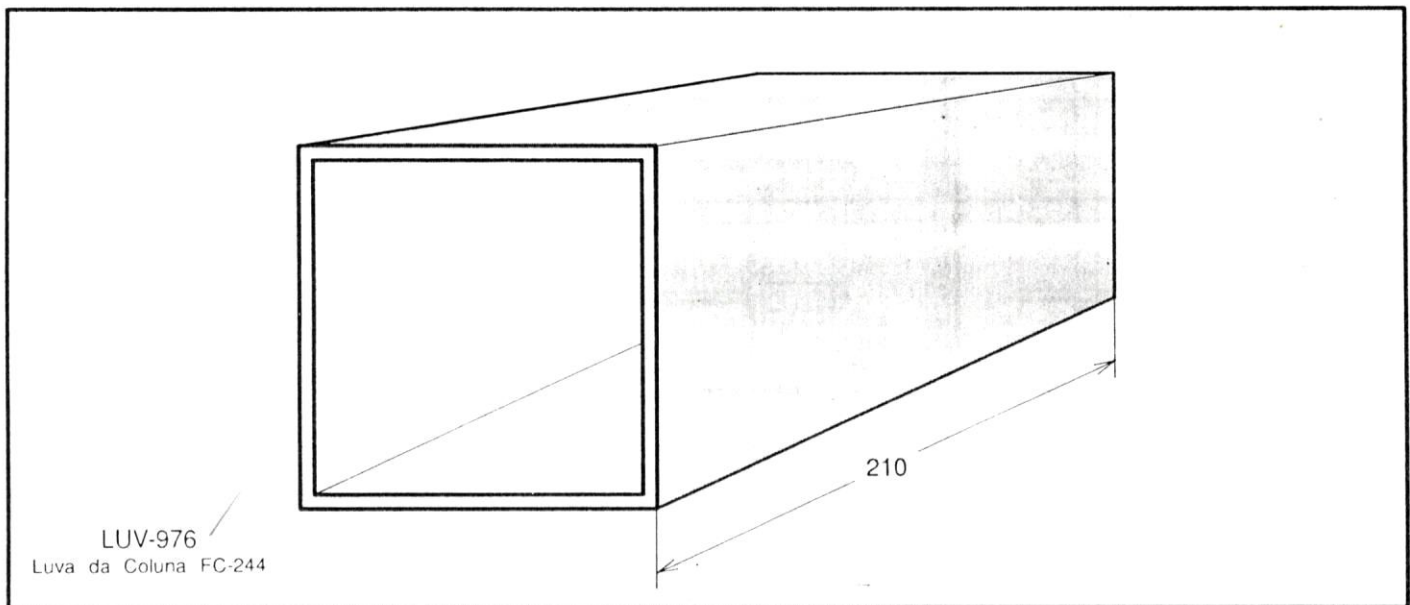
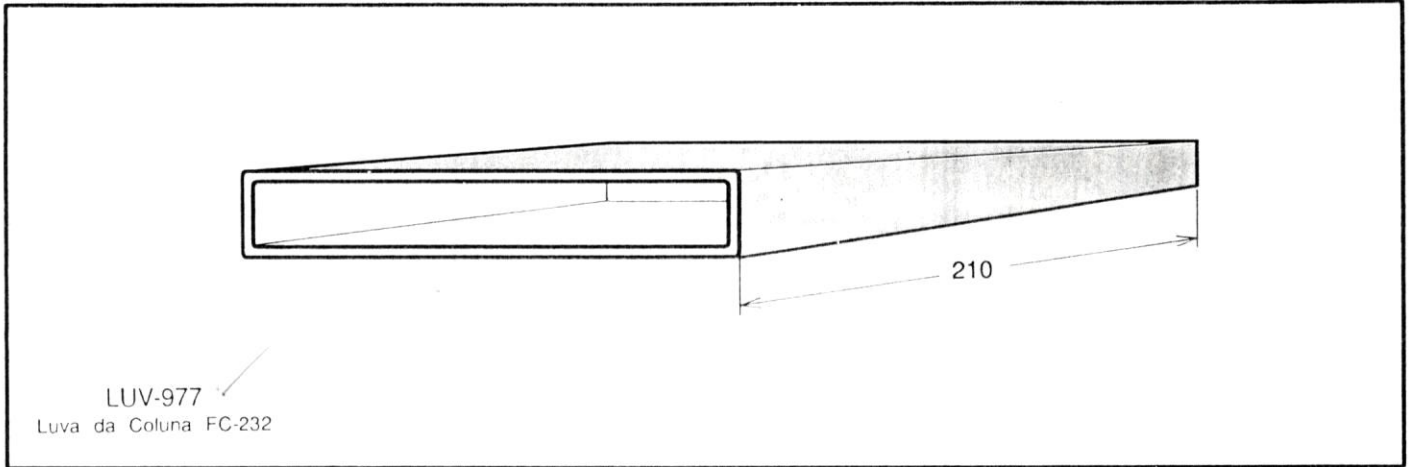

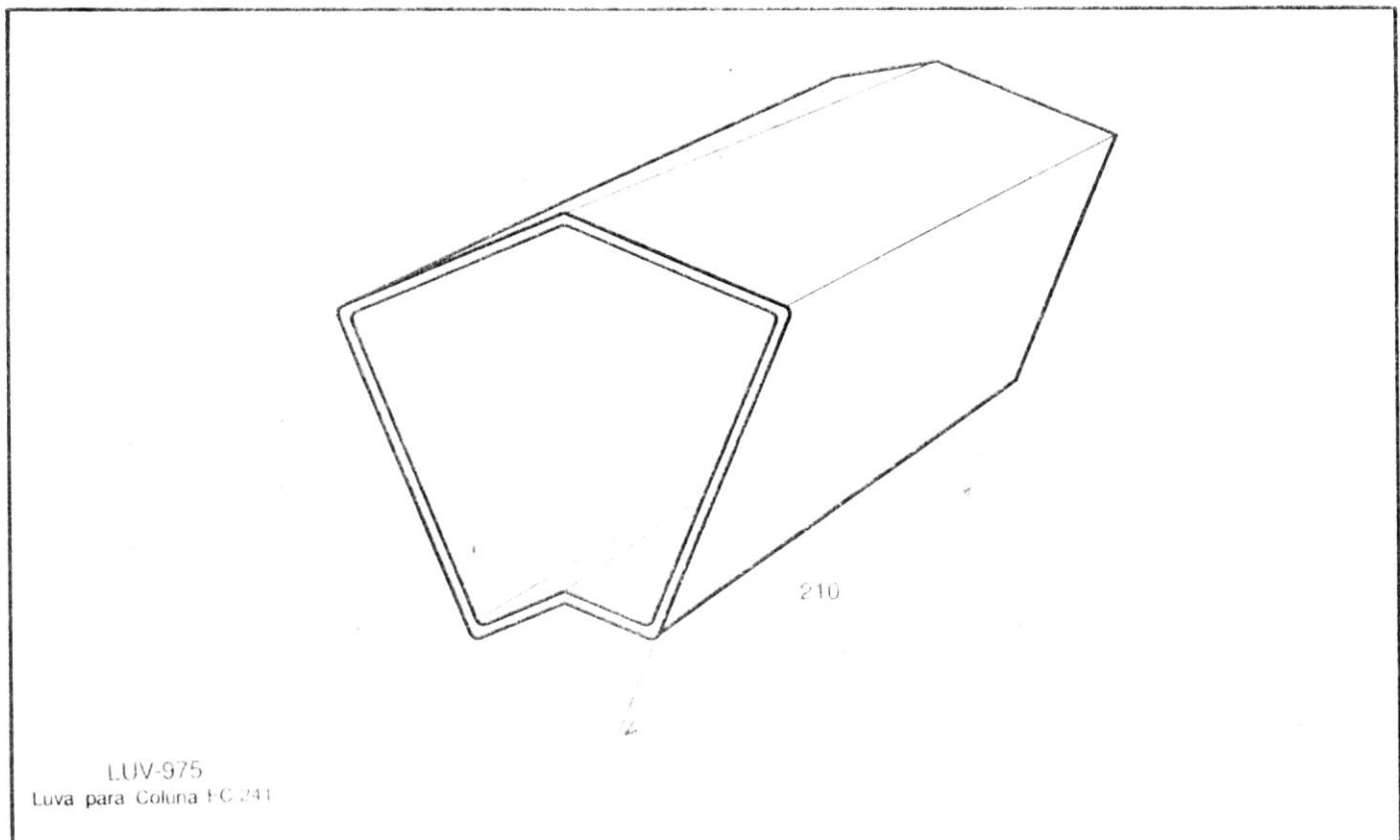
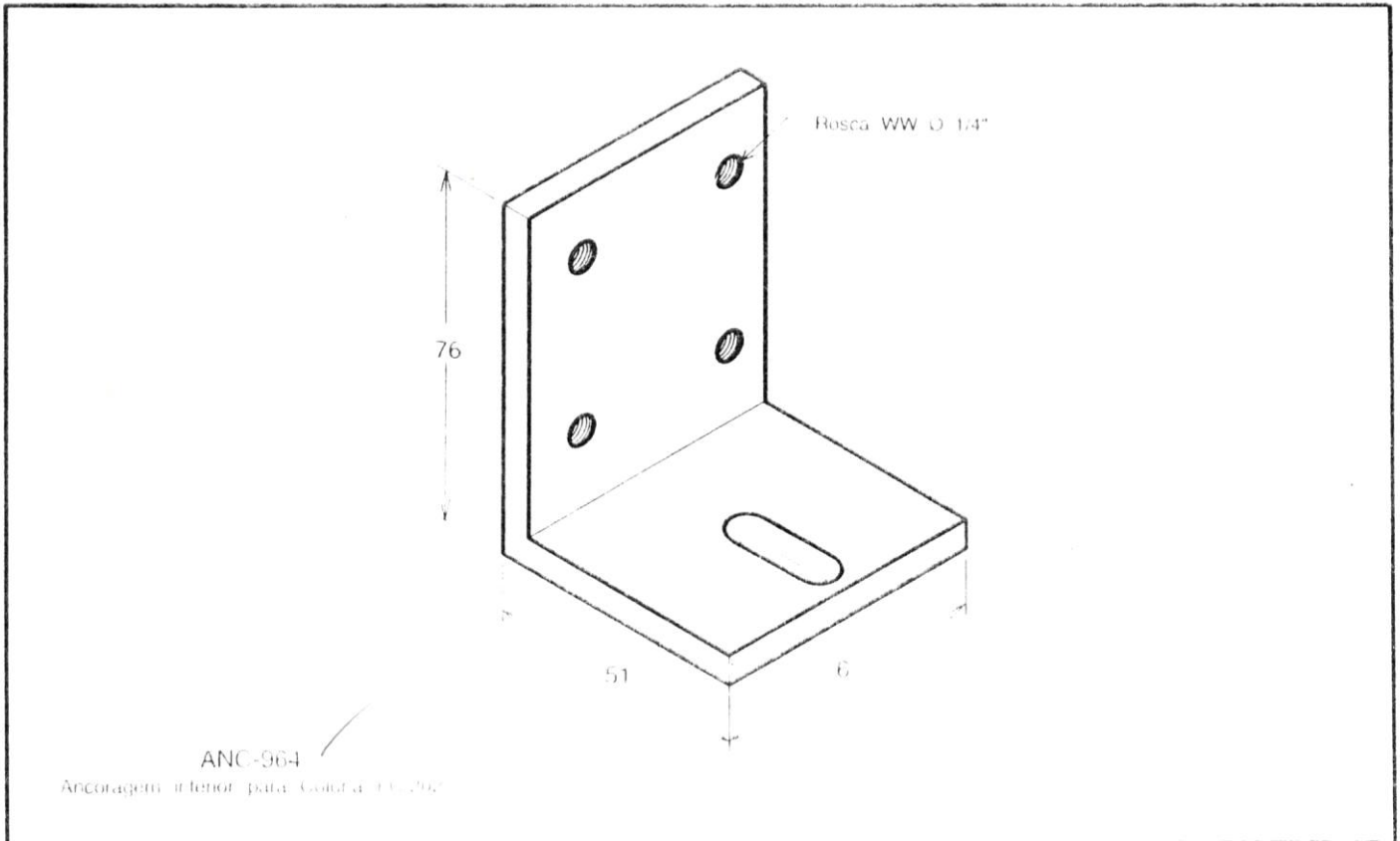

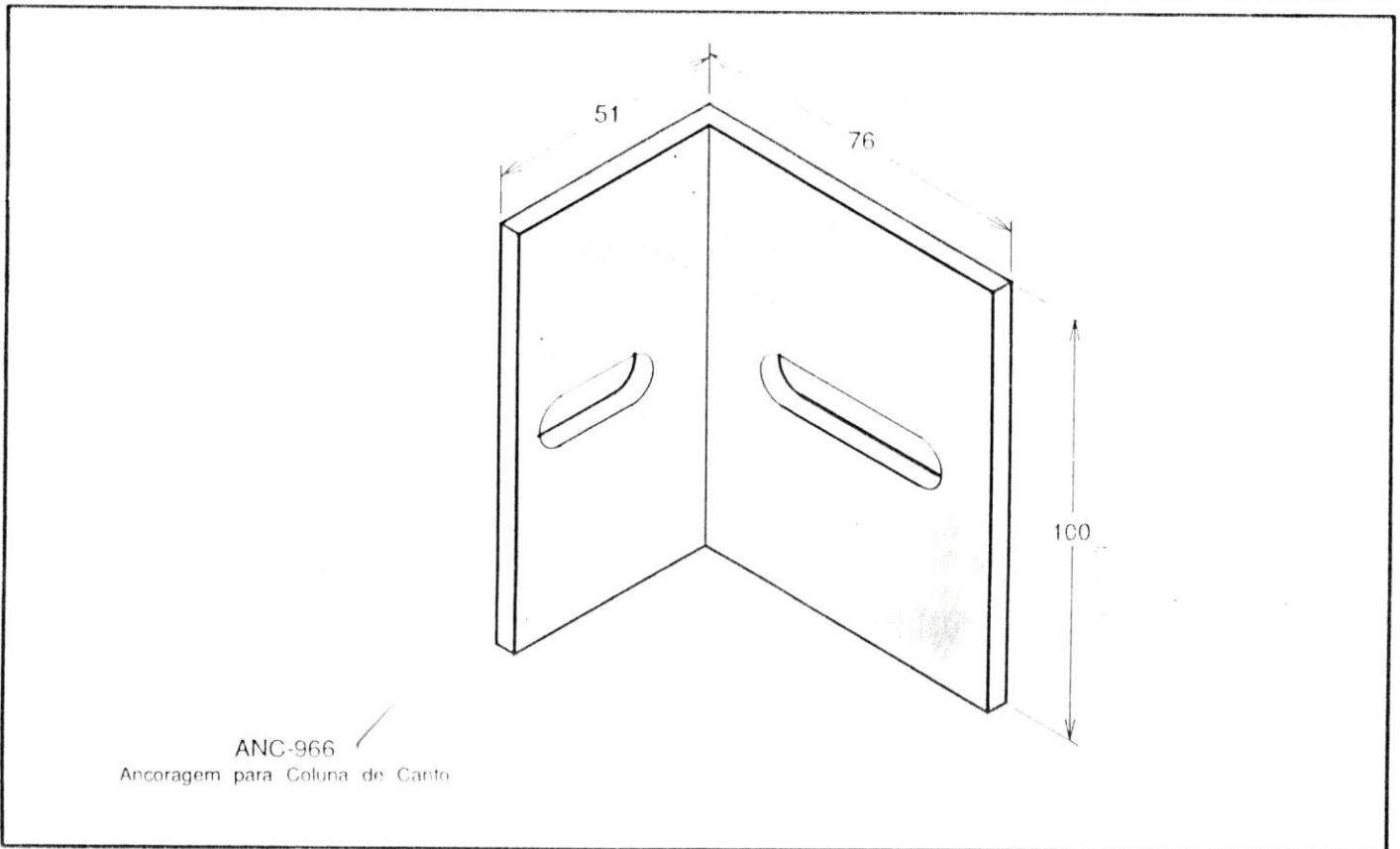
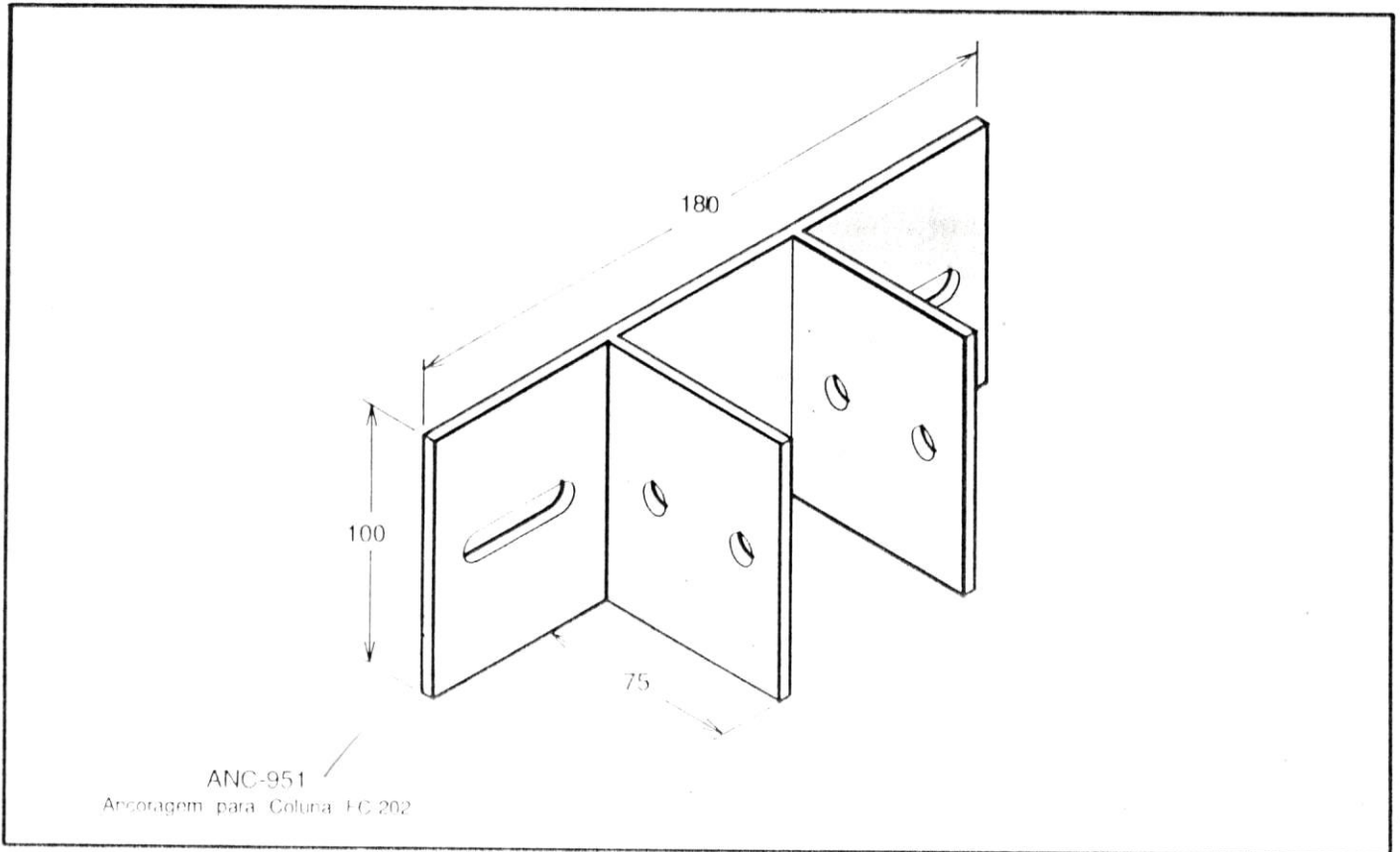

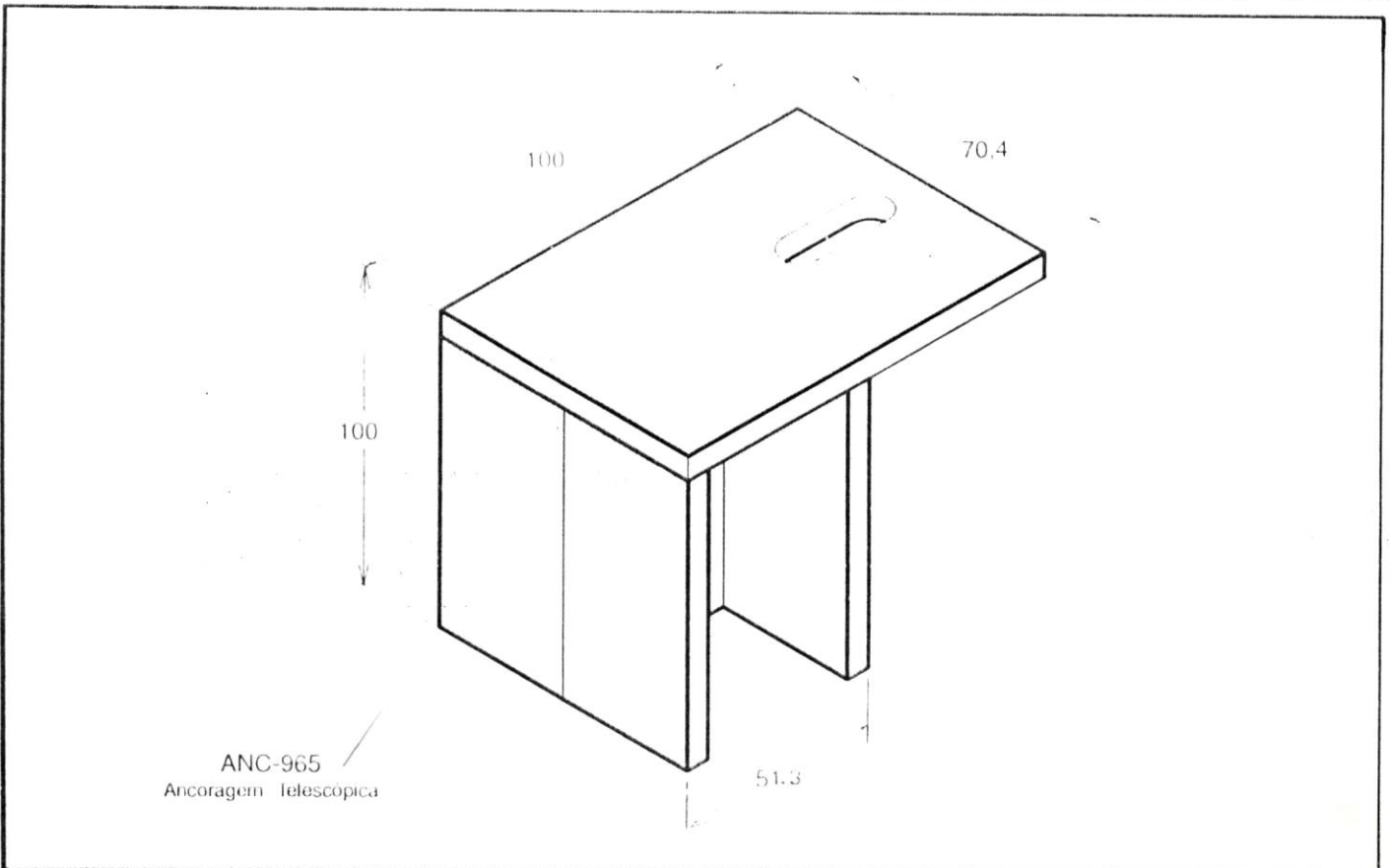
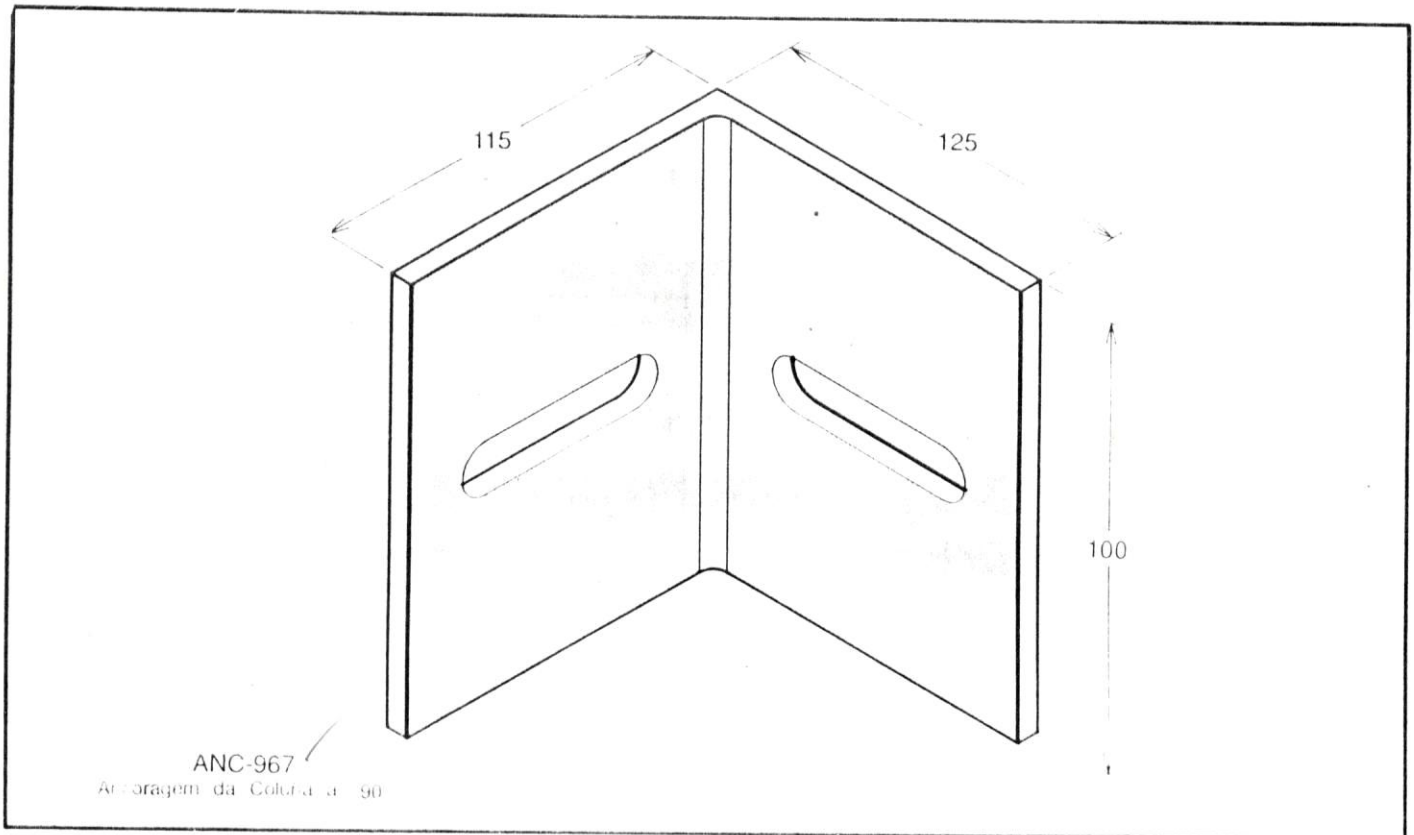

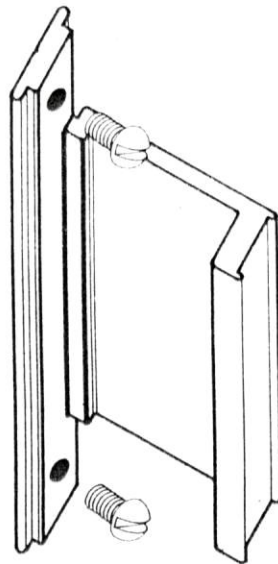

PRE-955
Presilha da Folha Fixa com Bagueira

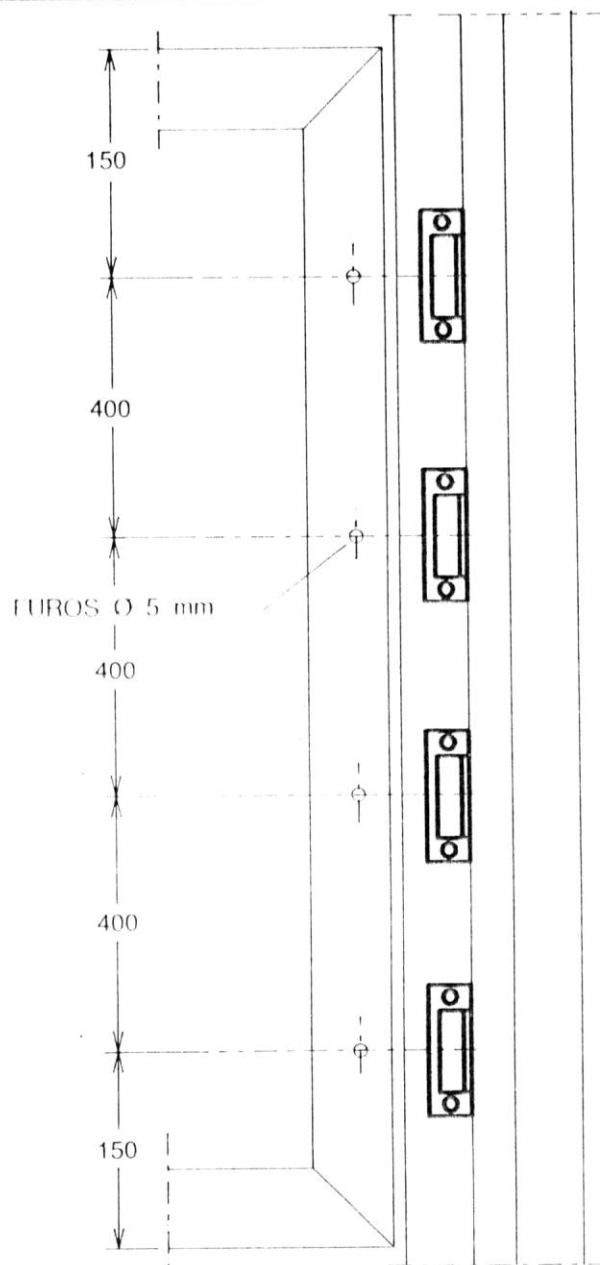

Detalhe do Posicionamento das Presilhas

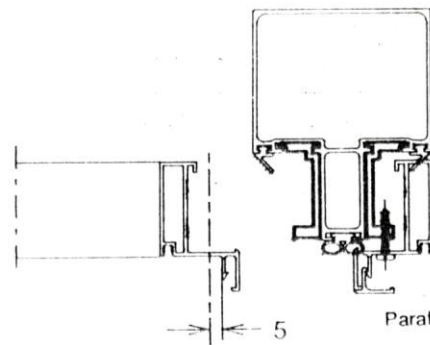

PAR-223
Paraf. c. p. Ø 4.2 x 25 mm
auto atarrachante

Parafuso Cabeça Redonda WW Ø 3/16 x 1/4
Aço Zincado

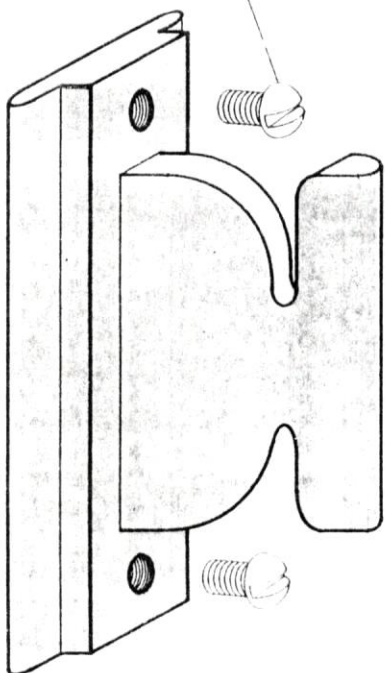

PRE-951 [Alumínio Natural]
Presilha da Coluna

Parafuso Cabeça Redonda WW Ø 3/16 x 1/4
Aço Zincado

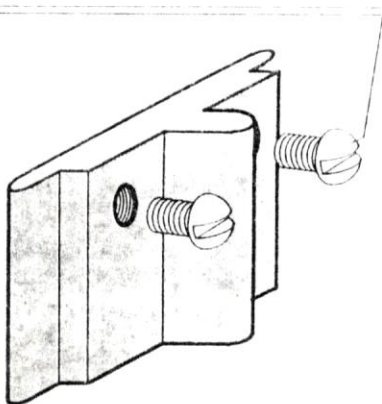

PRE-950 [Alumínio Natural]
Presilha da Folha Fixa

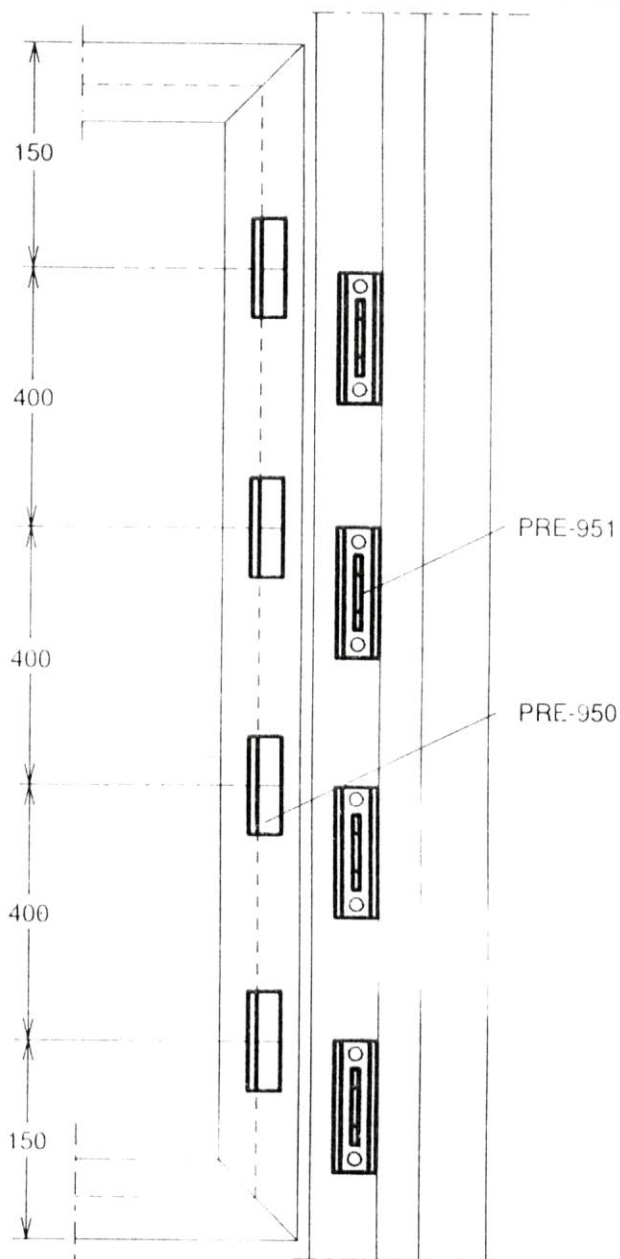

Detalhe do Posicionamento das Presilhas

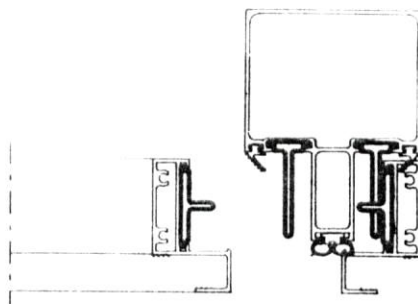

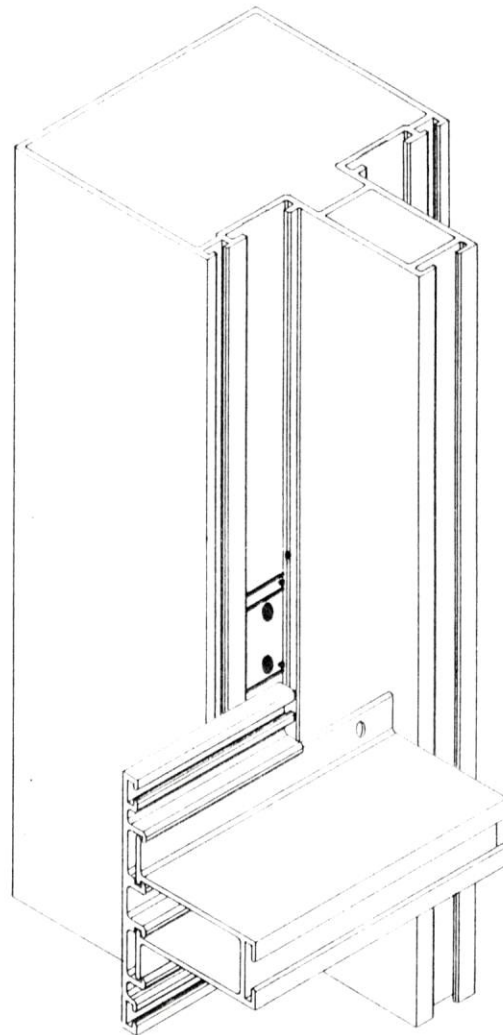

Parafuso Cabeça Redonda WW Ø 3/16 x 1/4
Aço Zincado

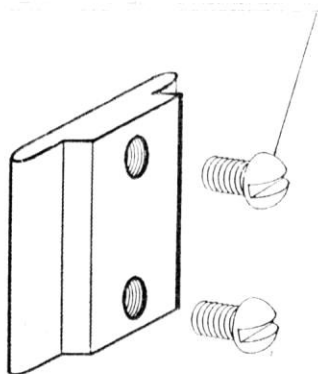

Detalhe de Fixação da Travessa

PRE-952

Presilha da Coluna e Travessa em Alumínio

Acessórios



Parafuso Cabeça Redonda WW Ø 3/16" x 1/4"
Aço Zincado

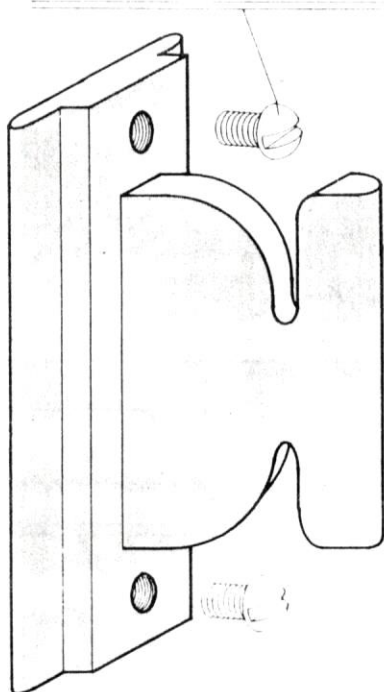

PRE-951 [Alumínio Natural]
Presilha de Coluna

Parafuso Cabeça Redonda WW Ø 3/16" x 1/4"
Aço Zincado

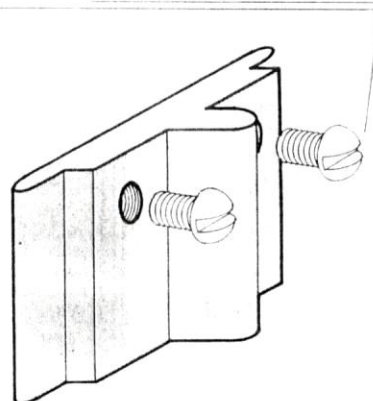

PRE-950 [Alumínio Natural]
Presilha da Folha fixa

Parafuso Cabeça Redonda WW Ø 3/16" x 1/4"
Aço Zincado

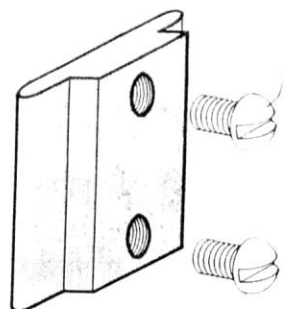

PRE-952 [Alumínio Natural]
Presilha da Coluna e Travessa

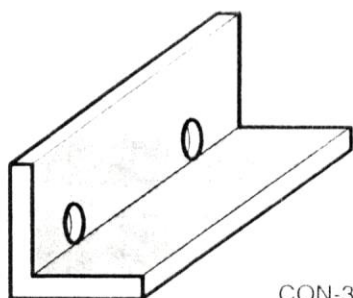

CON-361 [Alumínio Natural]
Cantoneira de Conexão da Folha

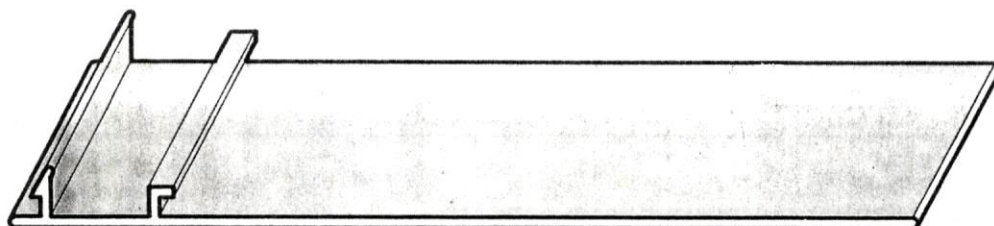

CHU-840
Chumbador em Alumínio

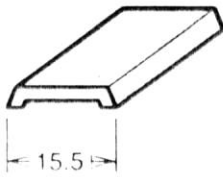

GUA-132
Guarnição em PVC - preto

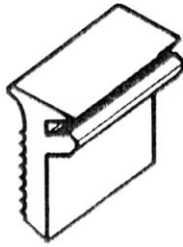

GUA-169
Guarnição p/ Vidro de 5 a 6 mm
em E.P.D.M. Dureza 65 ± 5 Shore

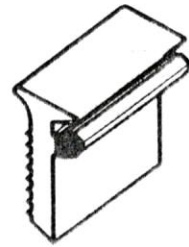

GUA-176
Guarnição p/ Vidro de 5 a 6 mm
em Santoprene Dureza 65 ± 5 Shore



GUA-168
Guarnição p/ Vidro de 5 a 6 mm
em E.P.D.M. Dureza 65 ± 5 Shore



GUA-175
Guarnição p/ Vidro de 5 a 6 mm
em Santoprene Dureza 65 ± 5 Shore

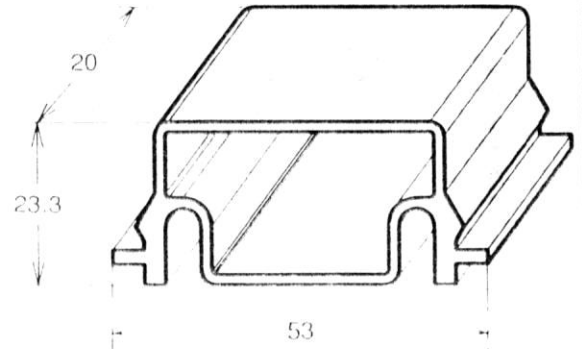

PRE-953
Presilha do Forro e Rodapé

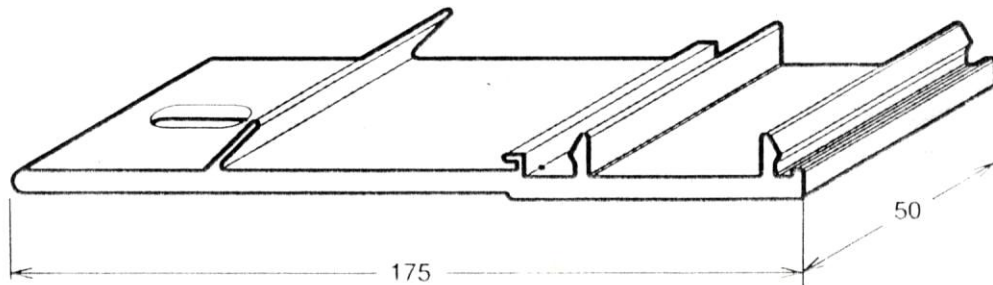

PRE-954
Presilha do Forro e Rodapé

Guarnição de Santoprene sob encomenda

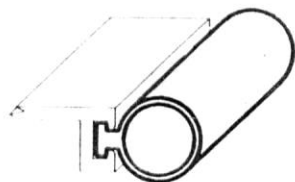

GUA-007
 Guarnição Opcional Superior Maxim - ar e Rodapê em E.P.D.M. Dureza 50 ± 5 shore

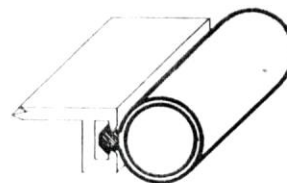

GUA-170
 Guarnição Opcional Superior Maxim - ar e Rodapê em Santoprene Dureza 65 ± 5 shore

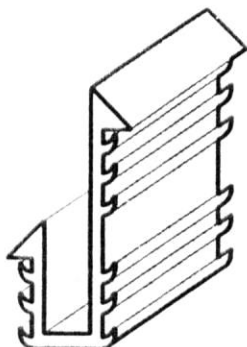

GUA-034
 Guarnição p/ Vidro de 5 a 6 mm em E.P.D.M. dureza 65 ± 5 Shore

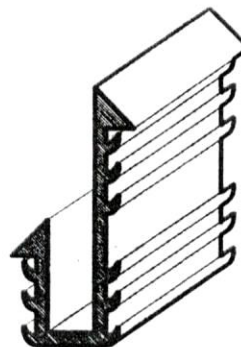

GUA-179
 Guarnição p/ Vidro de 5 a 6 mm em Santoprene Dureza 65 ± 5 Shore

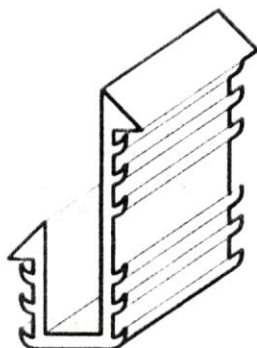

GUA-033
 Guarnição p/ Vidro de 7 a 8 mm em E.P.D.M. Dureza 65 ± 5 Shore

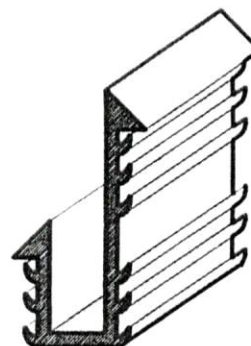

GUA-178
 Guarnição p/ Vidro de 7 a 8 mm em Santoprene Dureza 65 ± 5 Shore

Guarnição de Santoprene sob encomenda

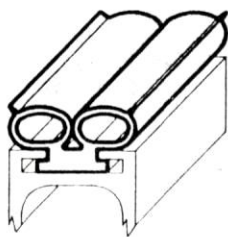

GUA-160
Guarnição da Coluna em E.P.D.M.
Dureza: 65 ±5 Shore

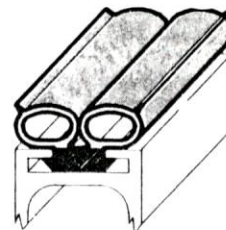

GUA -166
Guarnição da Coluna em Santoprene
Dureza: 65 ±5 Shore

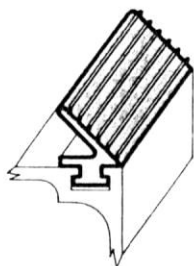

GUA-161
Guarnição p/ Vedação das folhas
em E.P.D.M. Dureza: 65 ±5 Shore

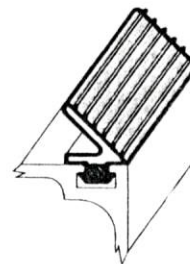

GUA-164
Guarnição p/ Vedação das folhas
em Santoprene. Dureza: 65 ±5 Shore

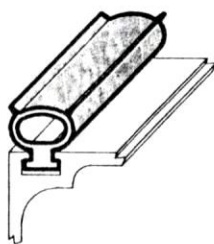

GUA-162
Guarnição da Coluna de Canto 90° e 135°
em E.P.D.M. Dureza 65 ±5 Shore

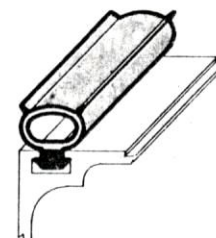

GUA-165
Guarnição da Coluna de Canto 90° e 135°
em Santoprene Dureza 65 ±5 Shore

Guarnição de Santoprene sob encomenda